

Abbildungen der Spirituellen Welten

(entsprechend der Anordnung von „Pticha le Chochmat ha Kabbala“)

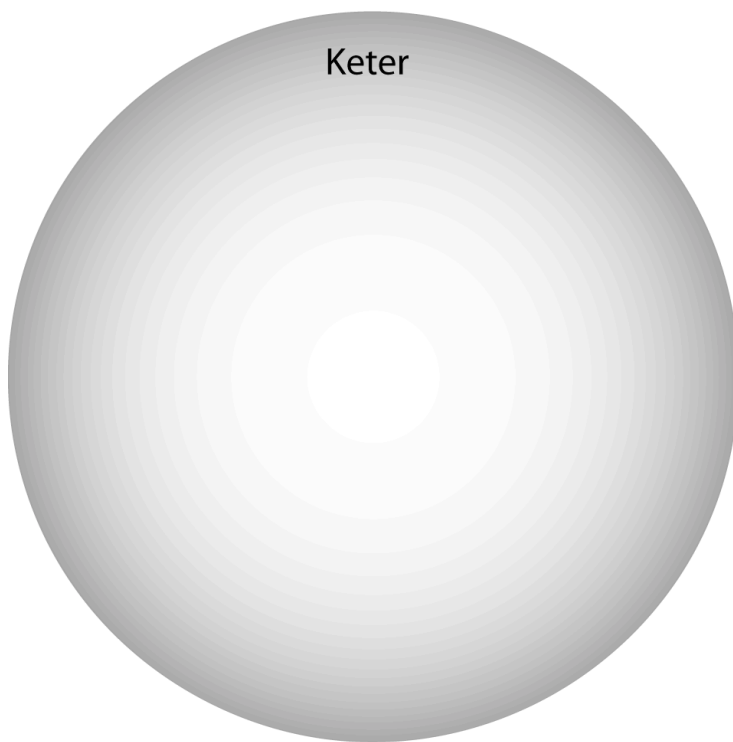

Azmuto



Bchina Shoresch
Keter

Abbildung 1. Vier Bchinot (Phasen). Bchina Shoresch.
(Einführung in die Weisheit der Kabbala, Punkt 5)

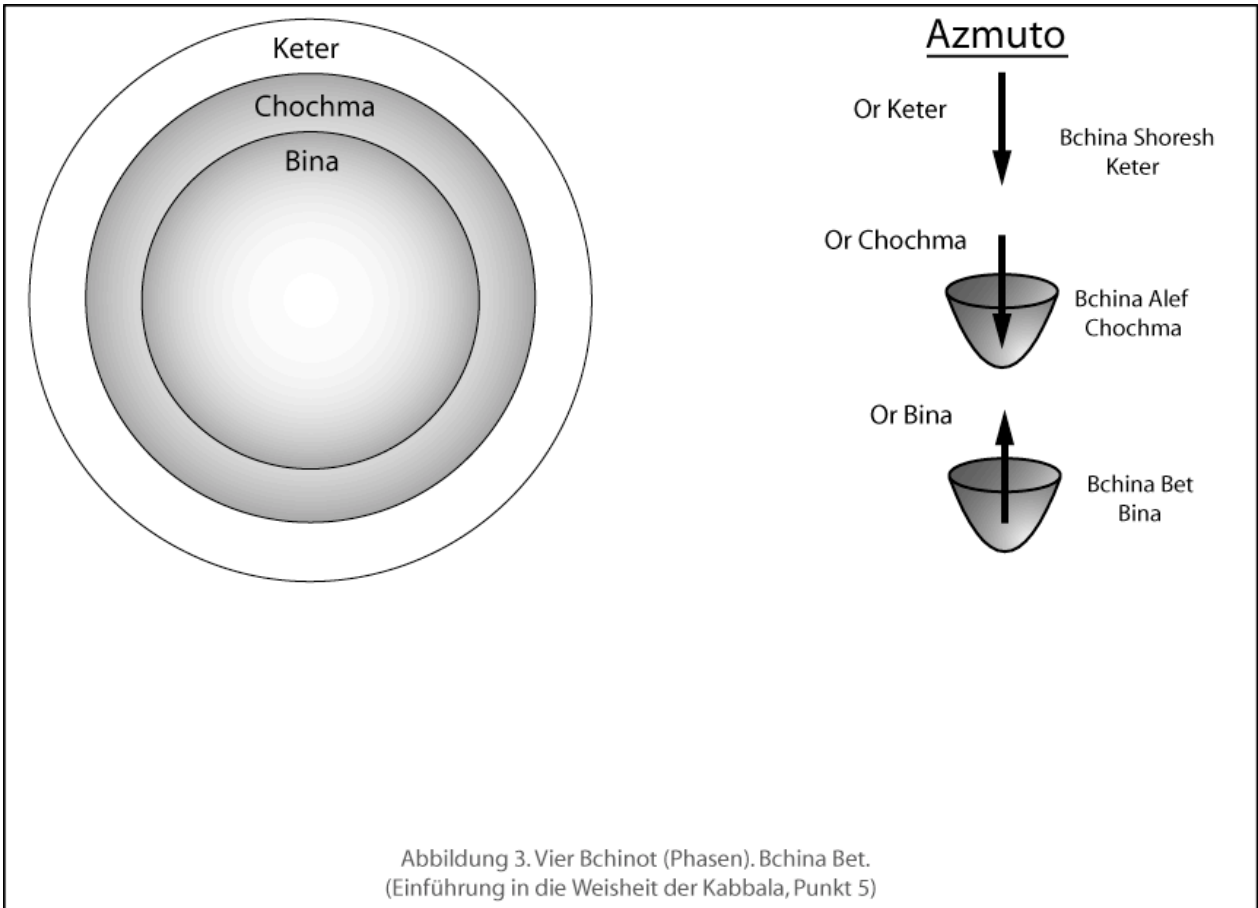
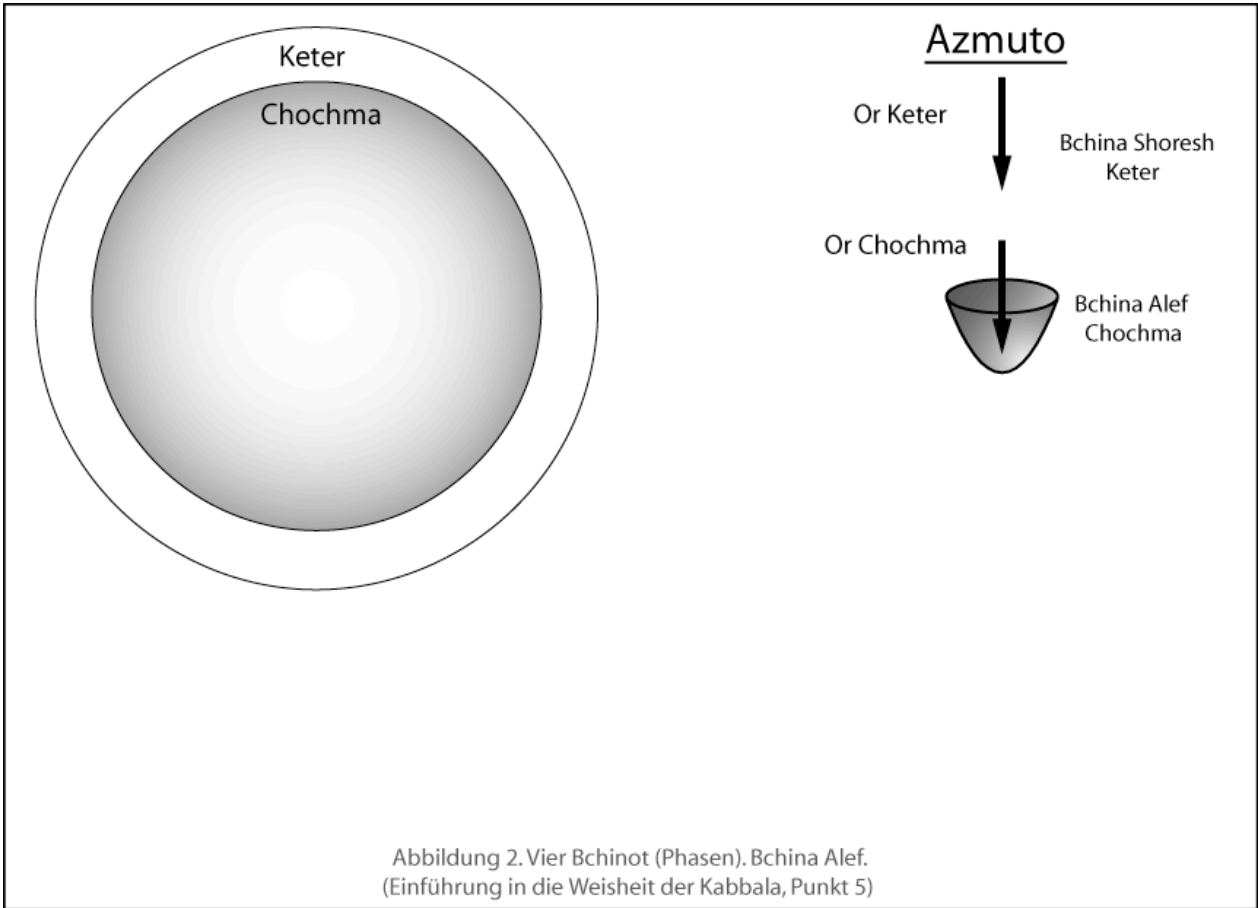

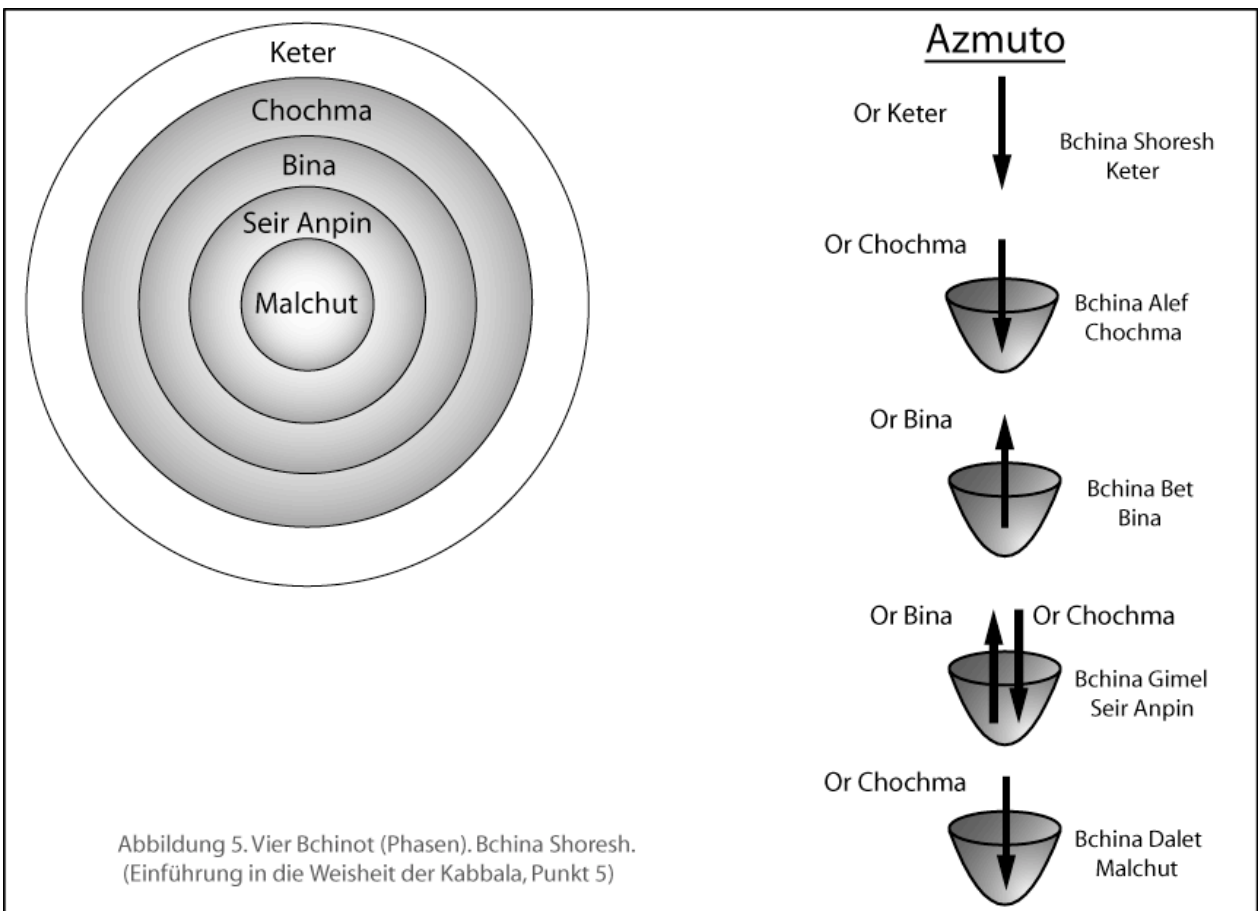
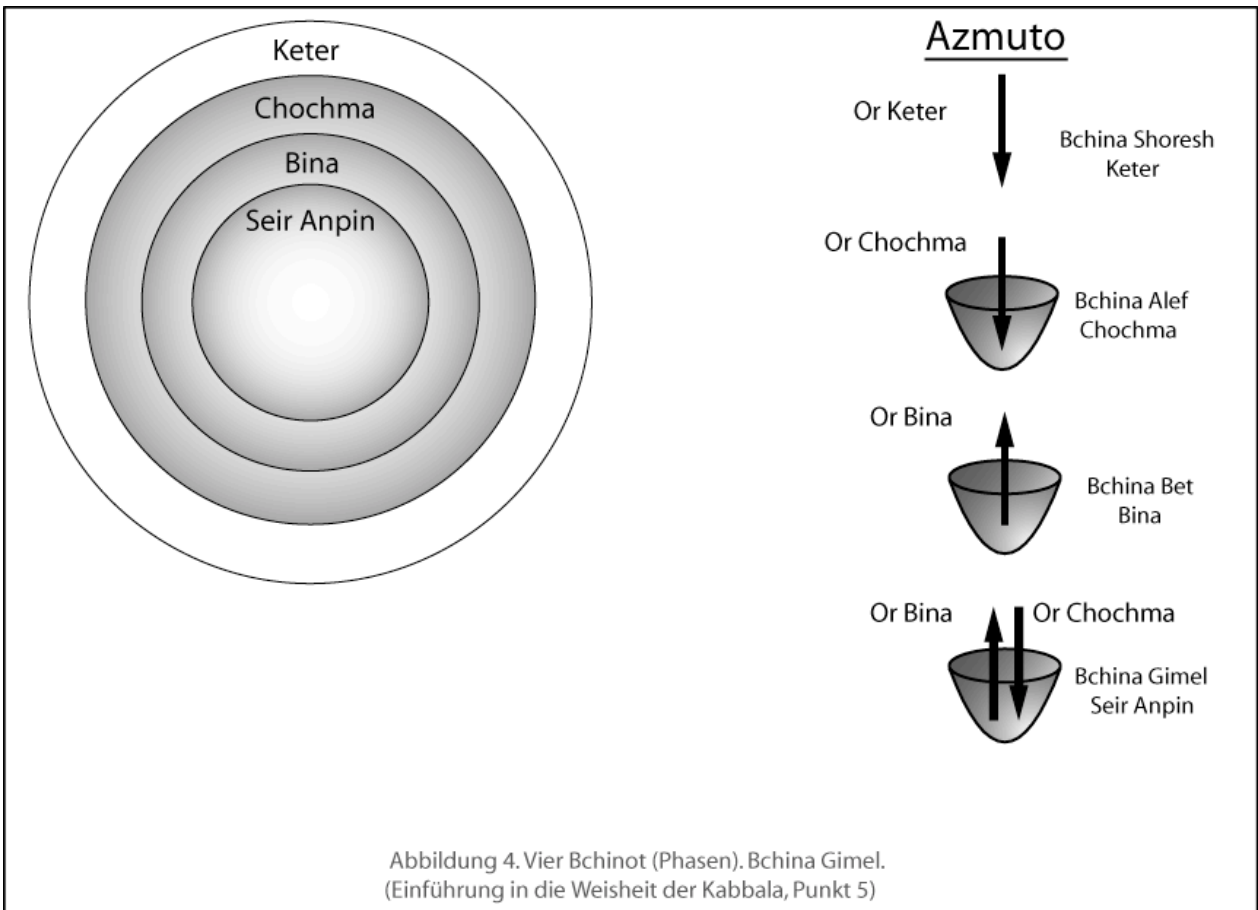

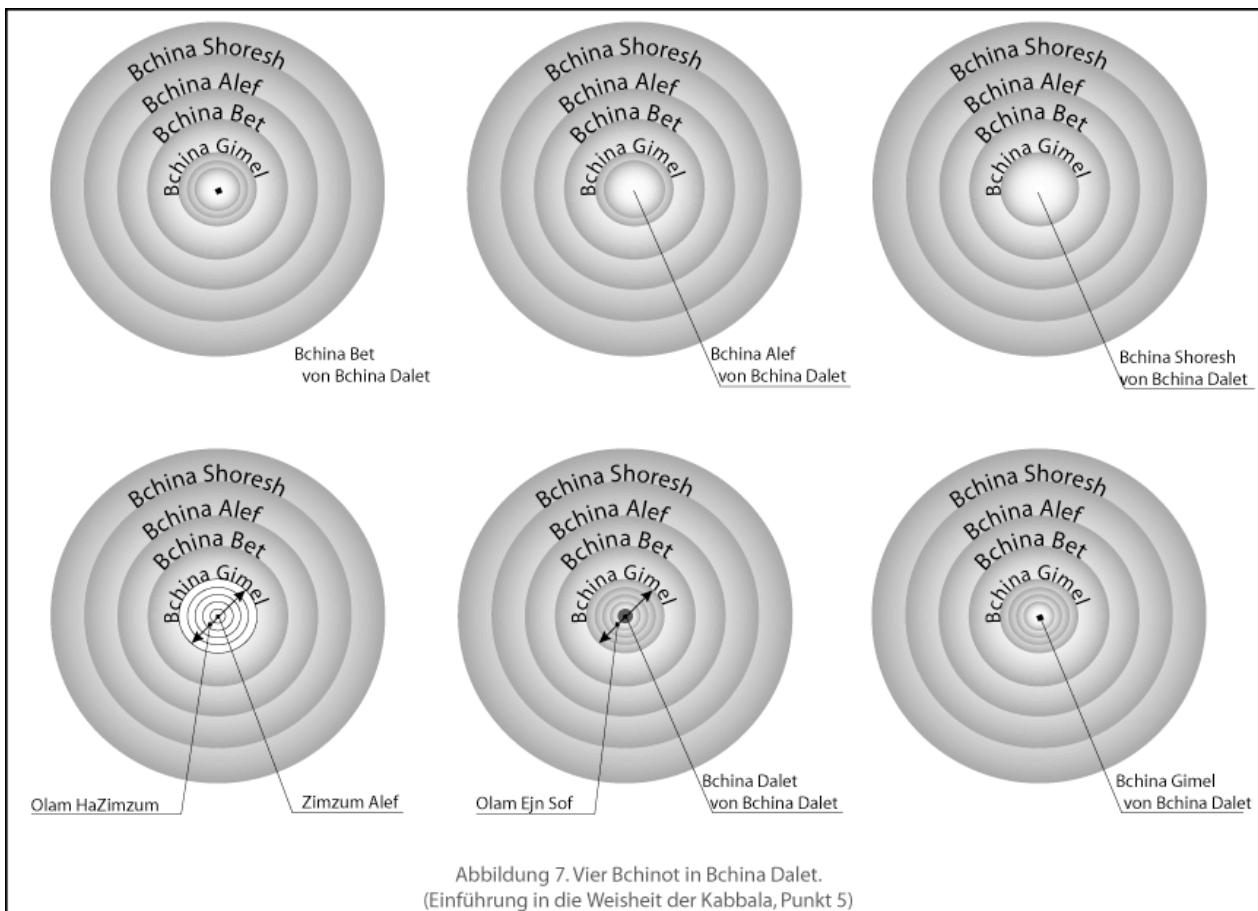
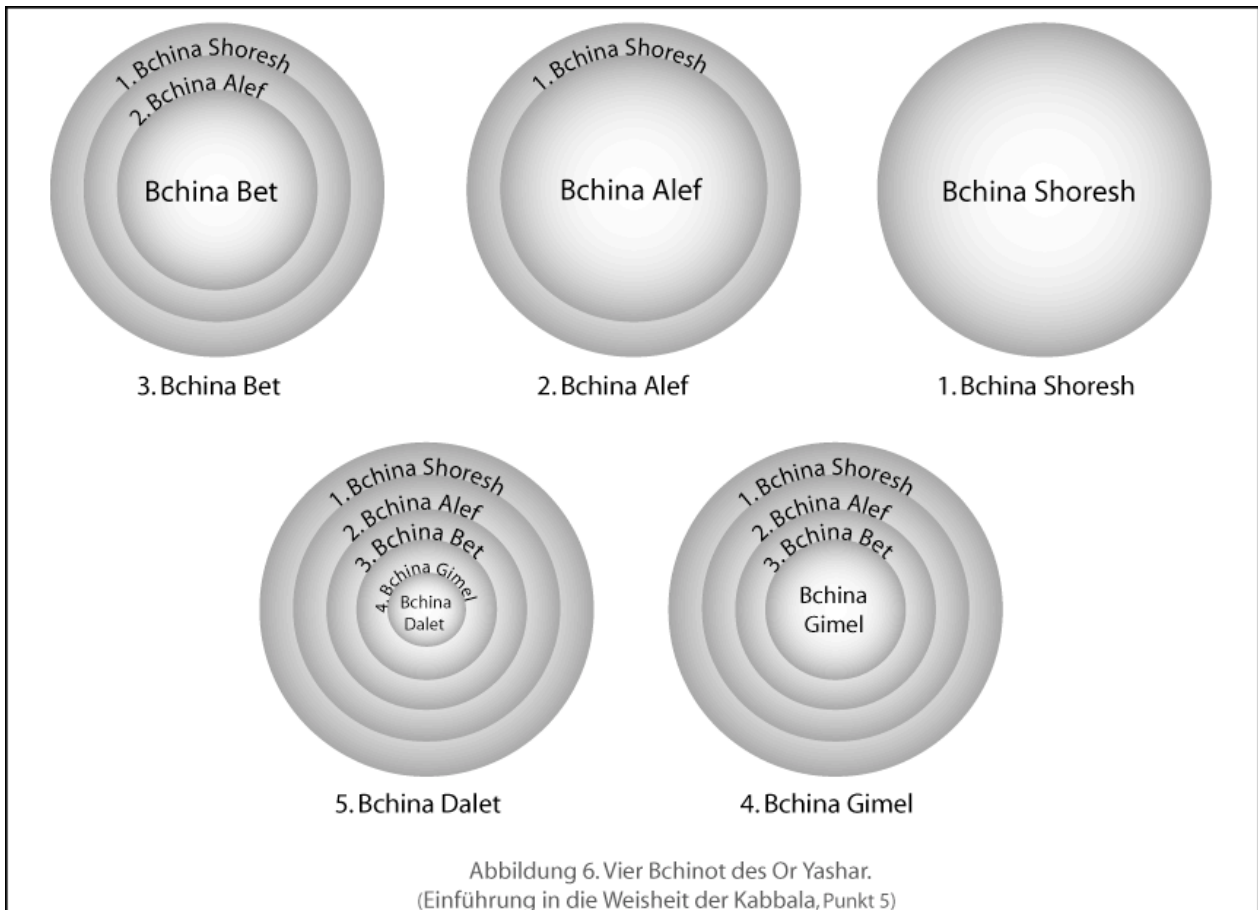

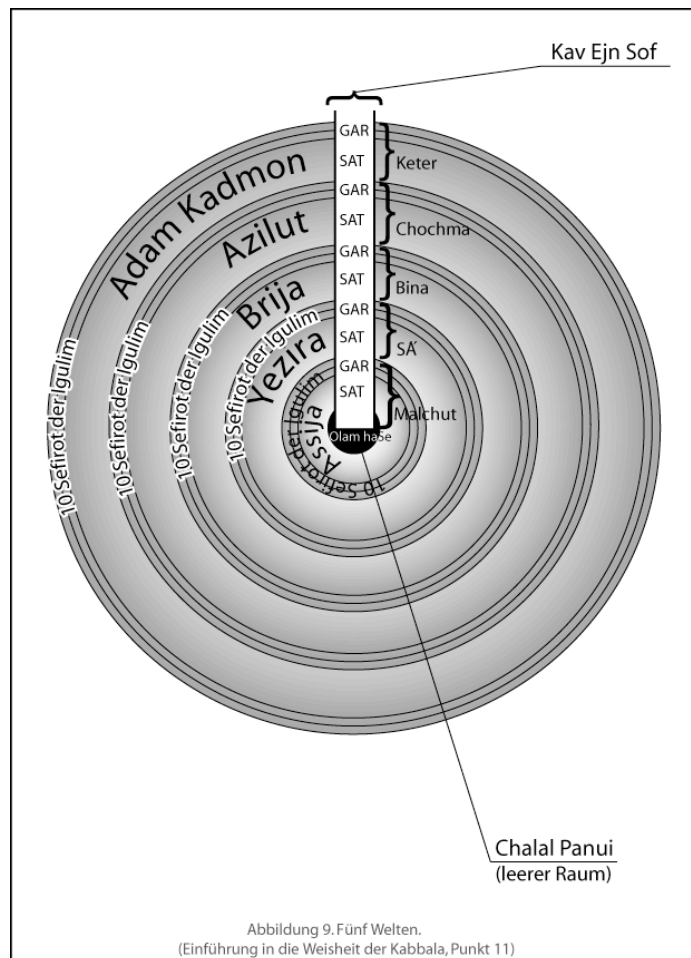
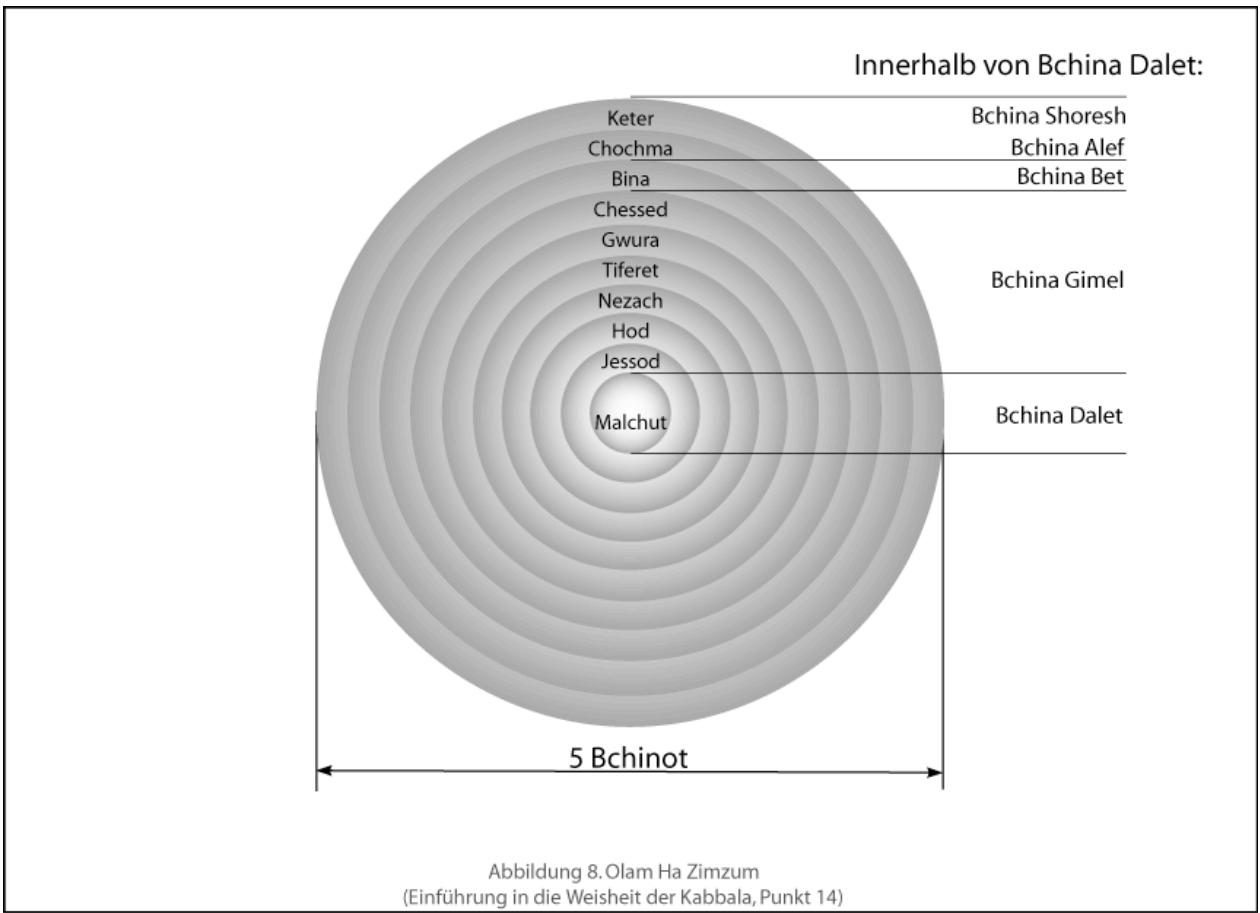

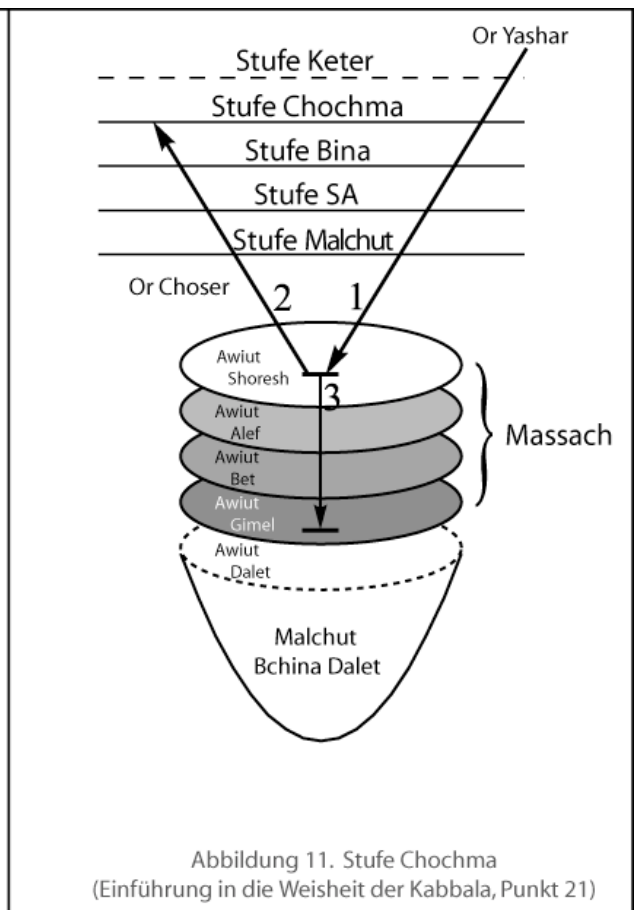
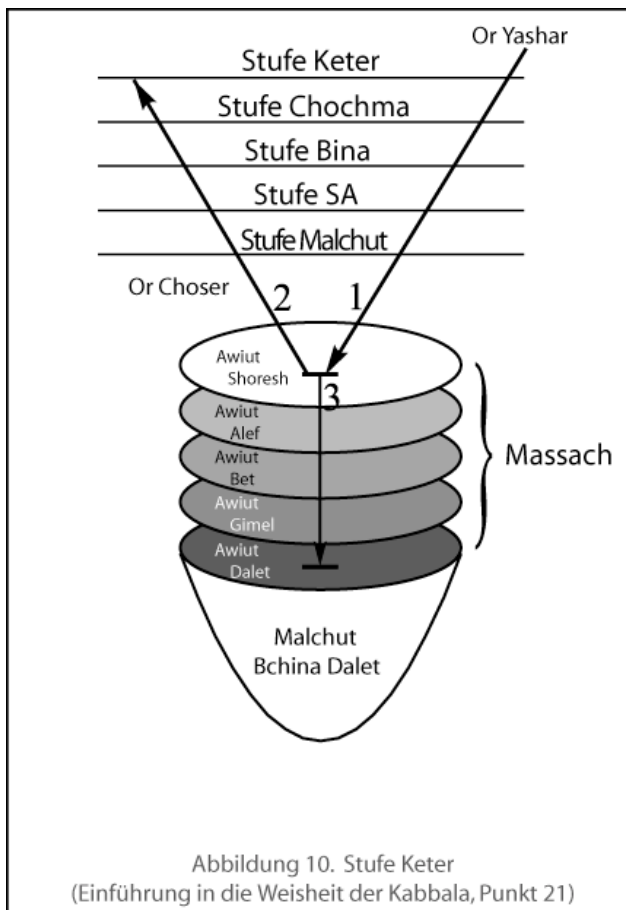
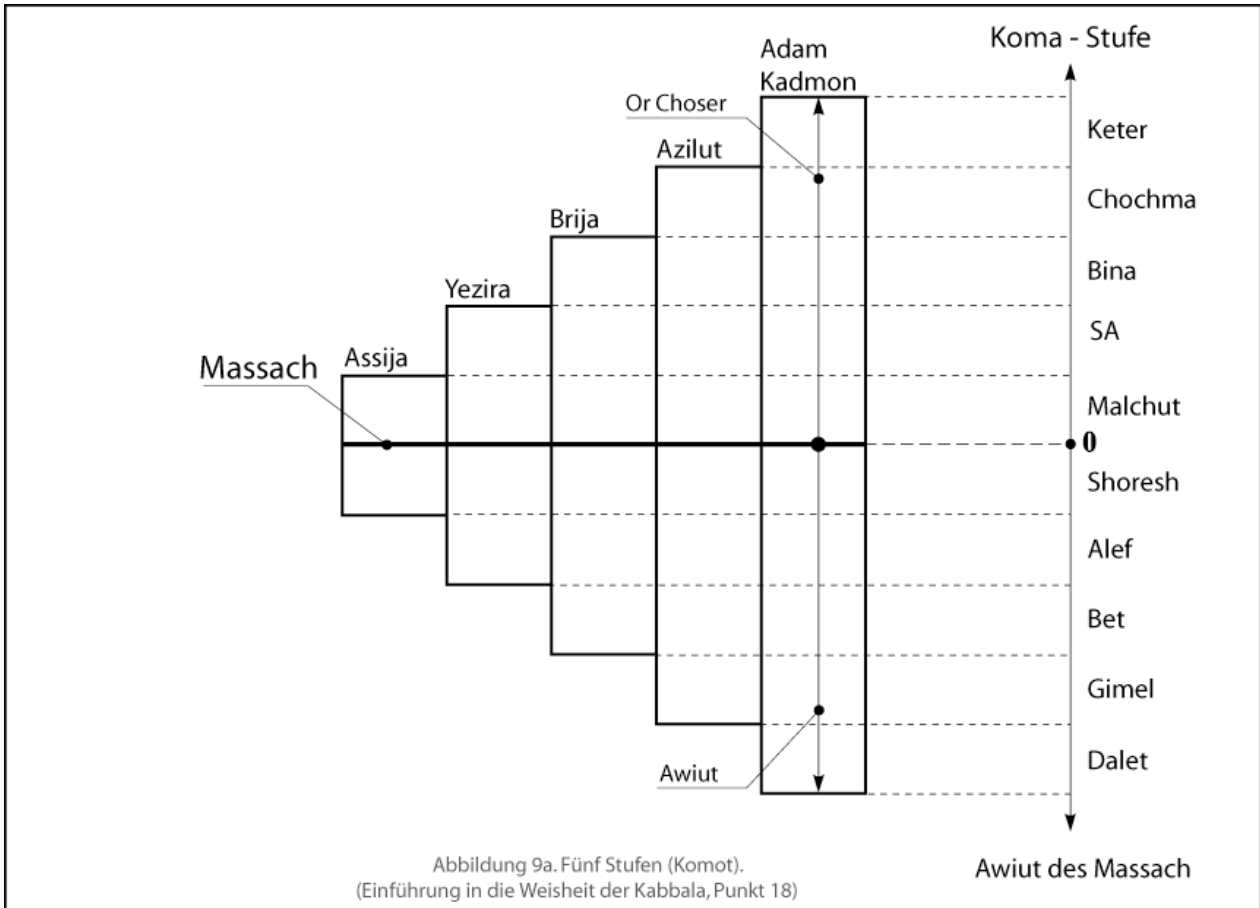

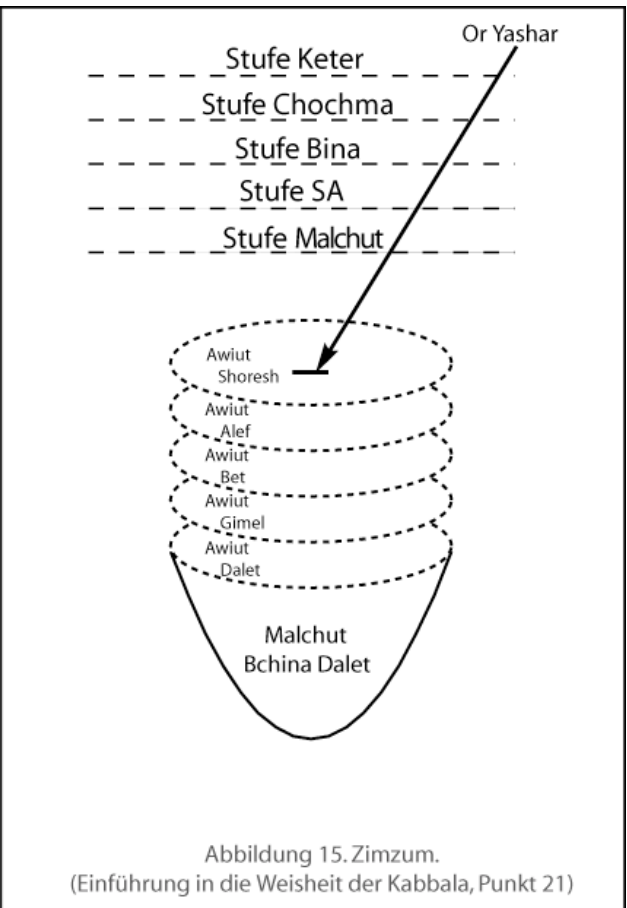
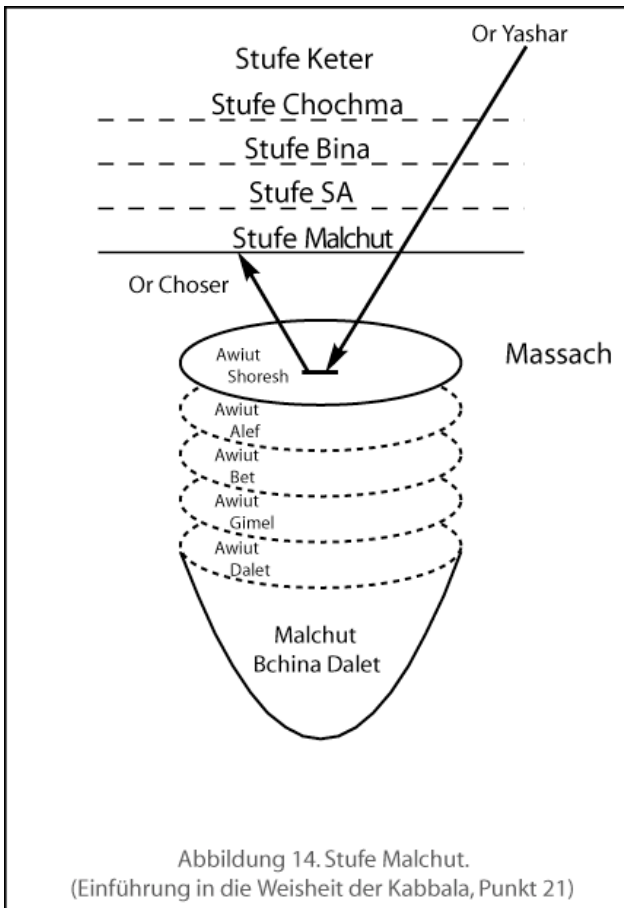
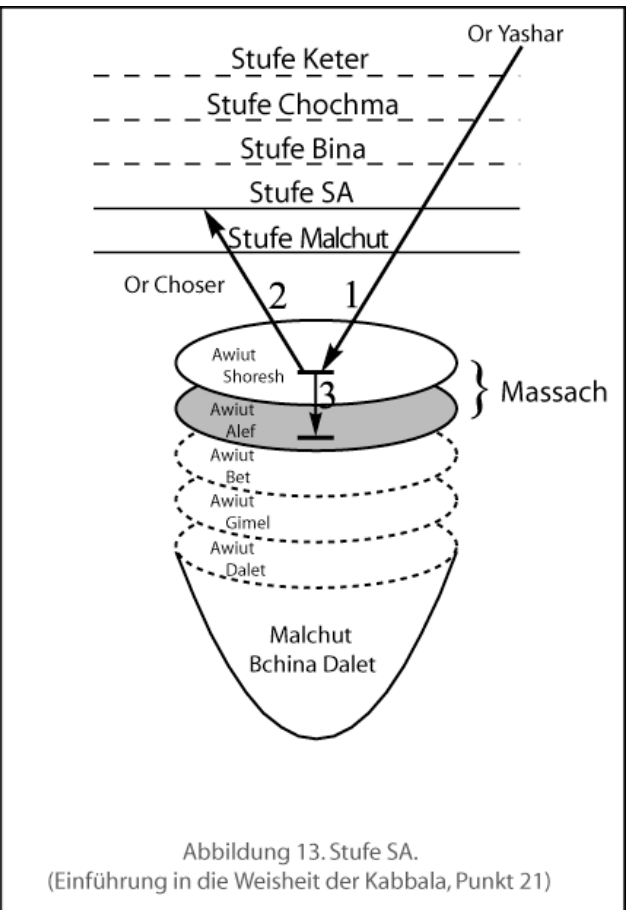
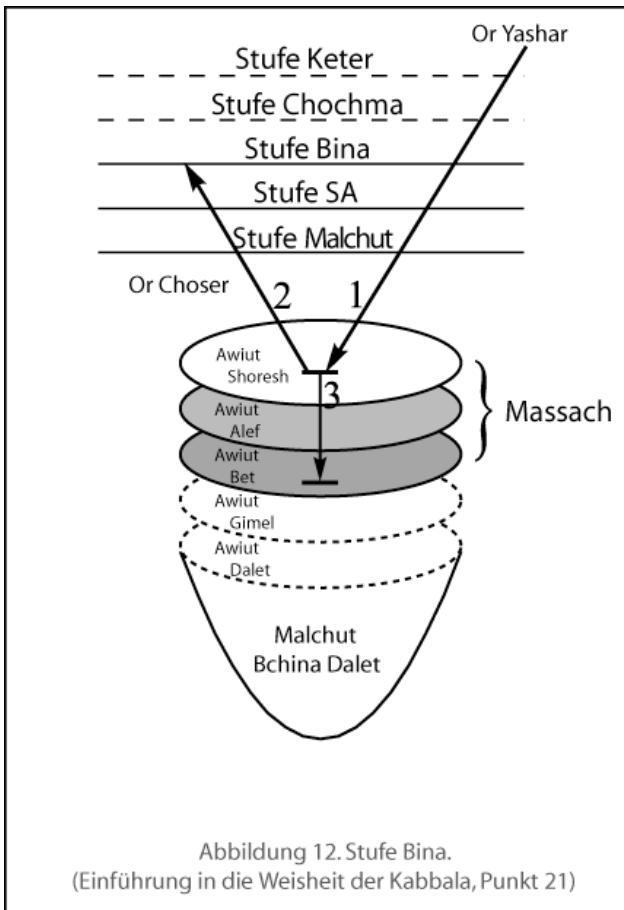

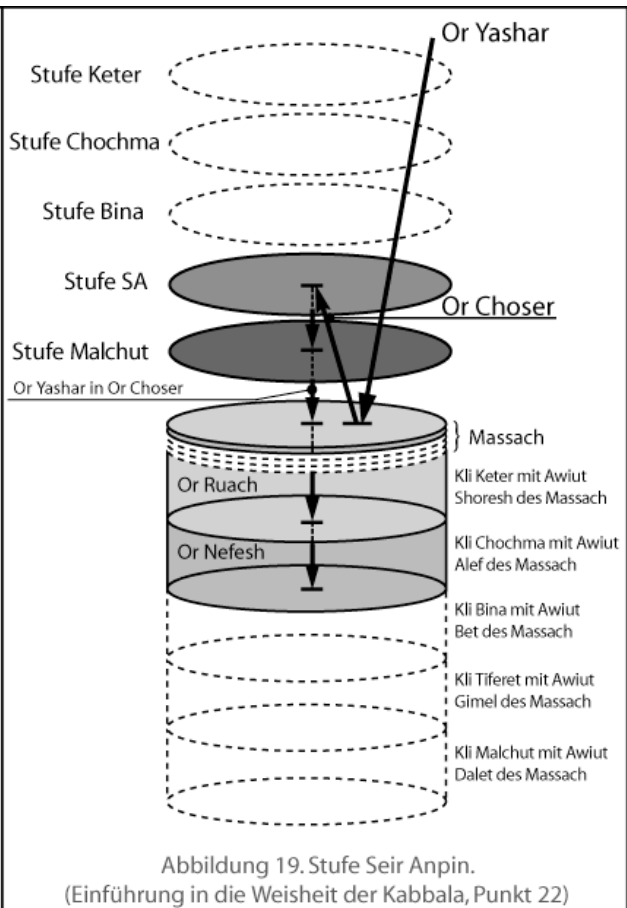
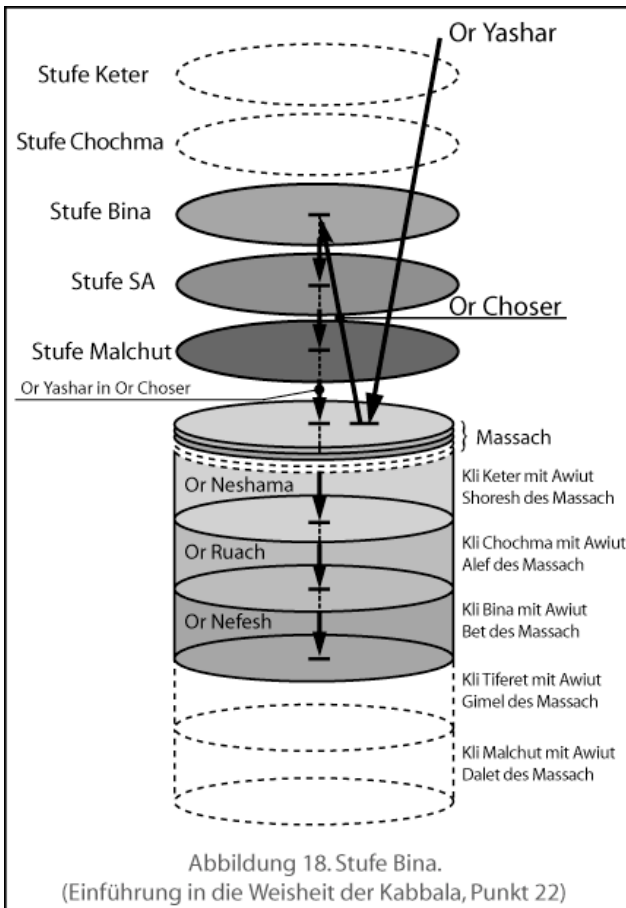
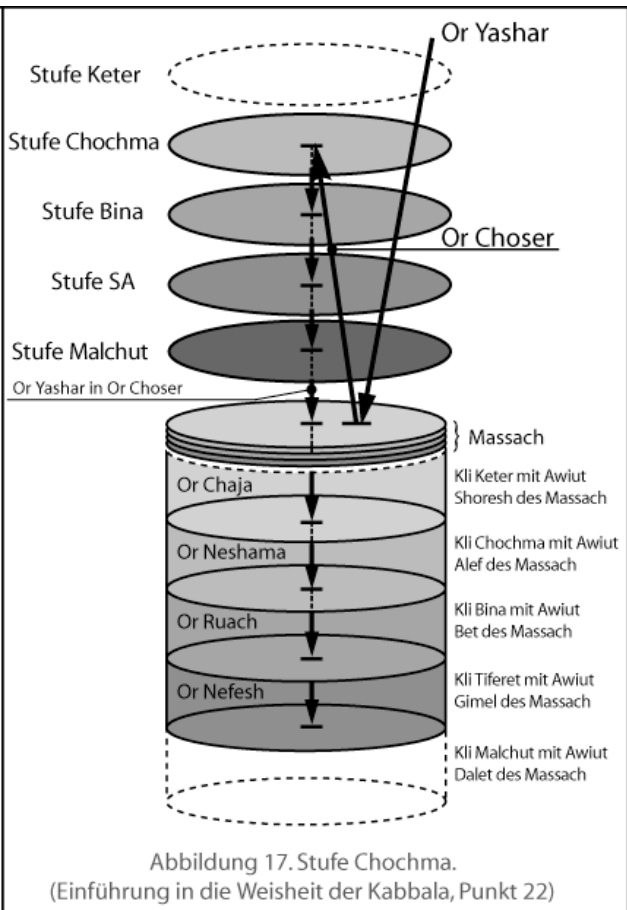
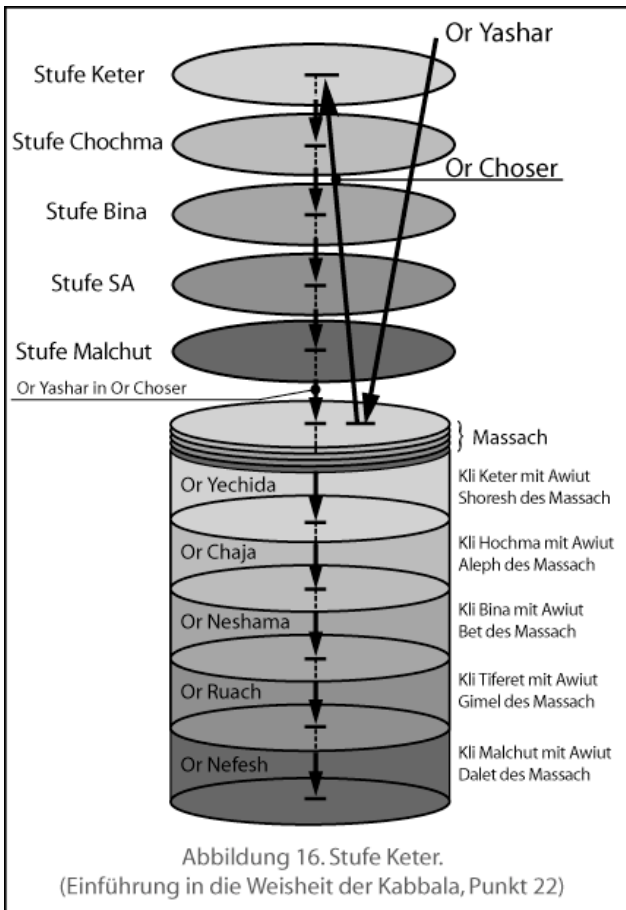

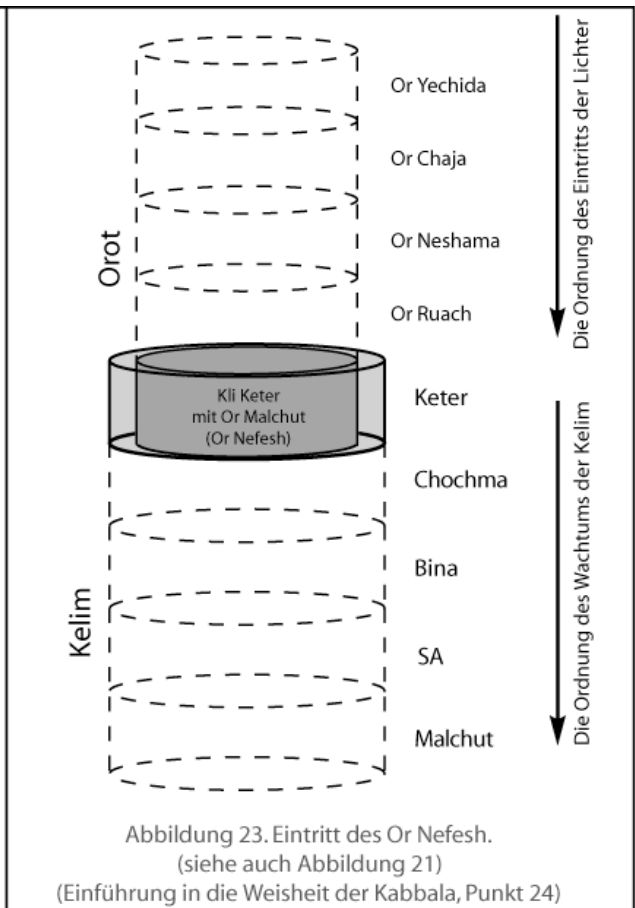
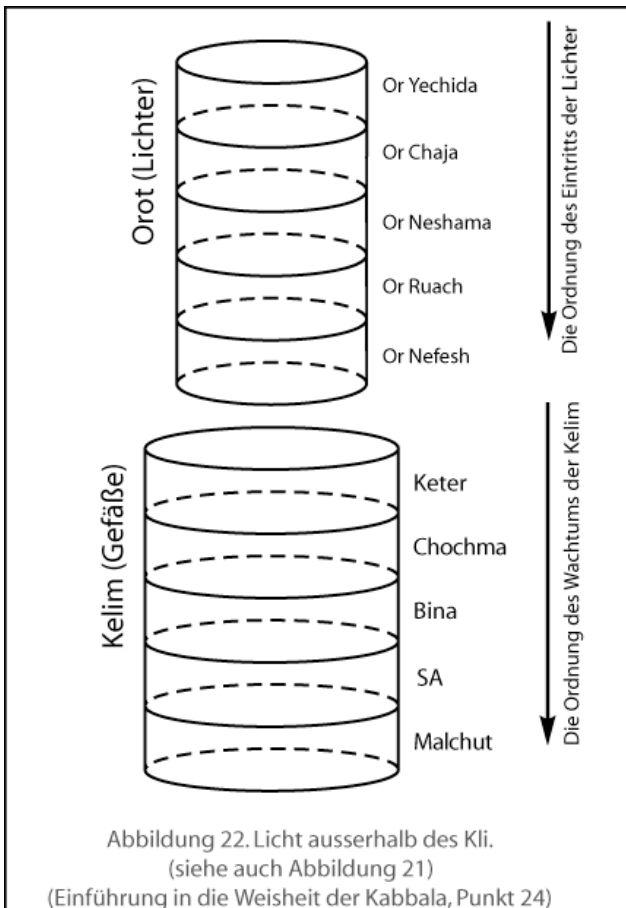
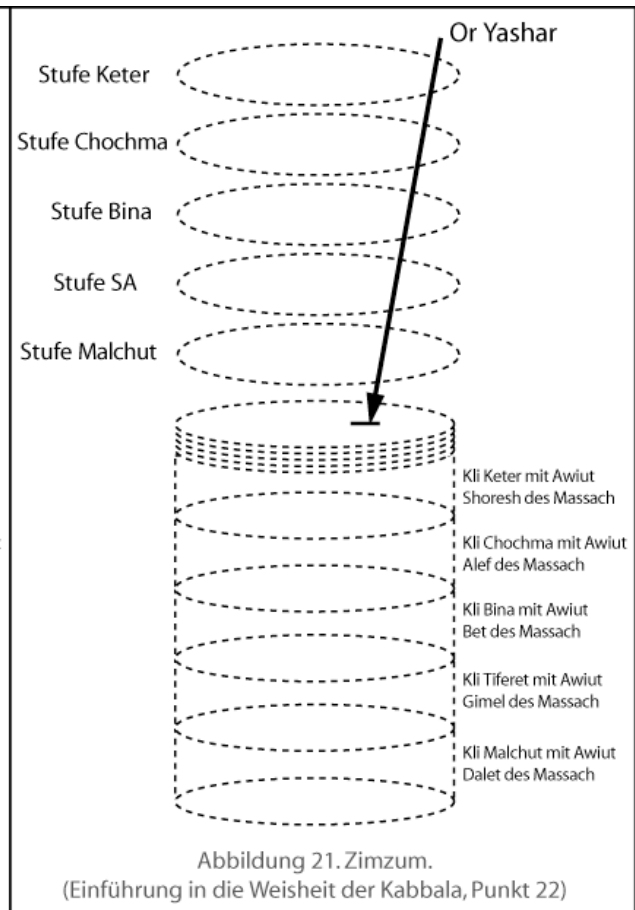
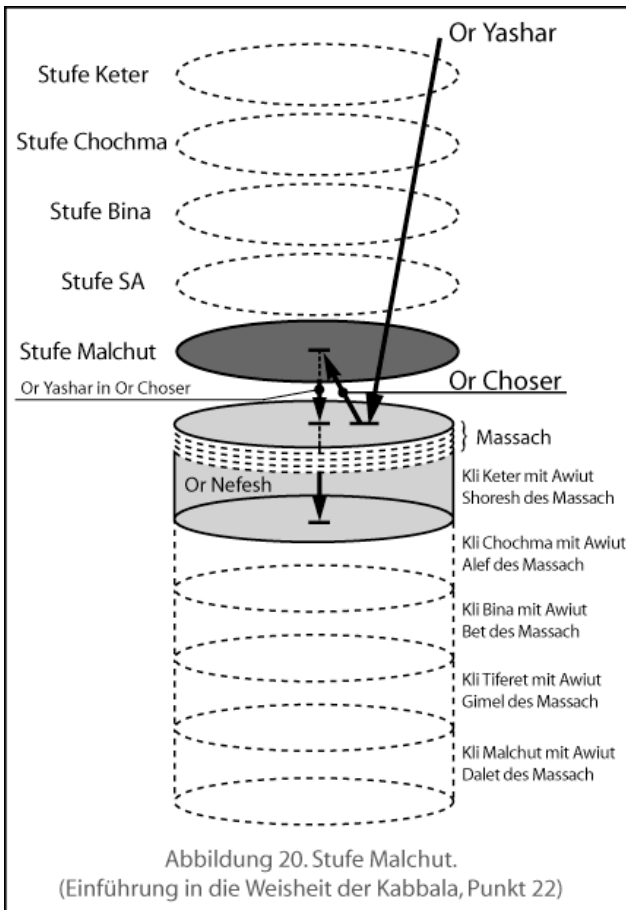

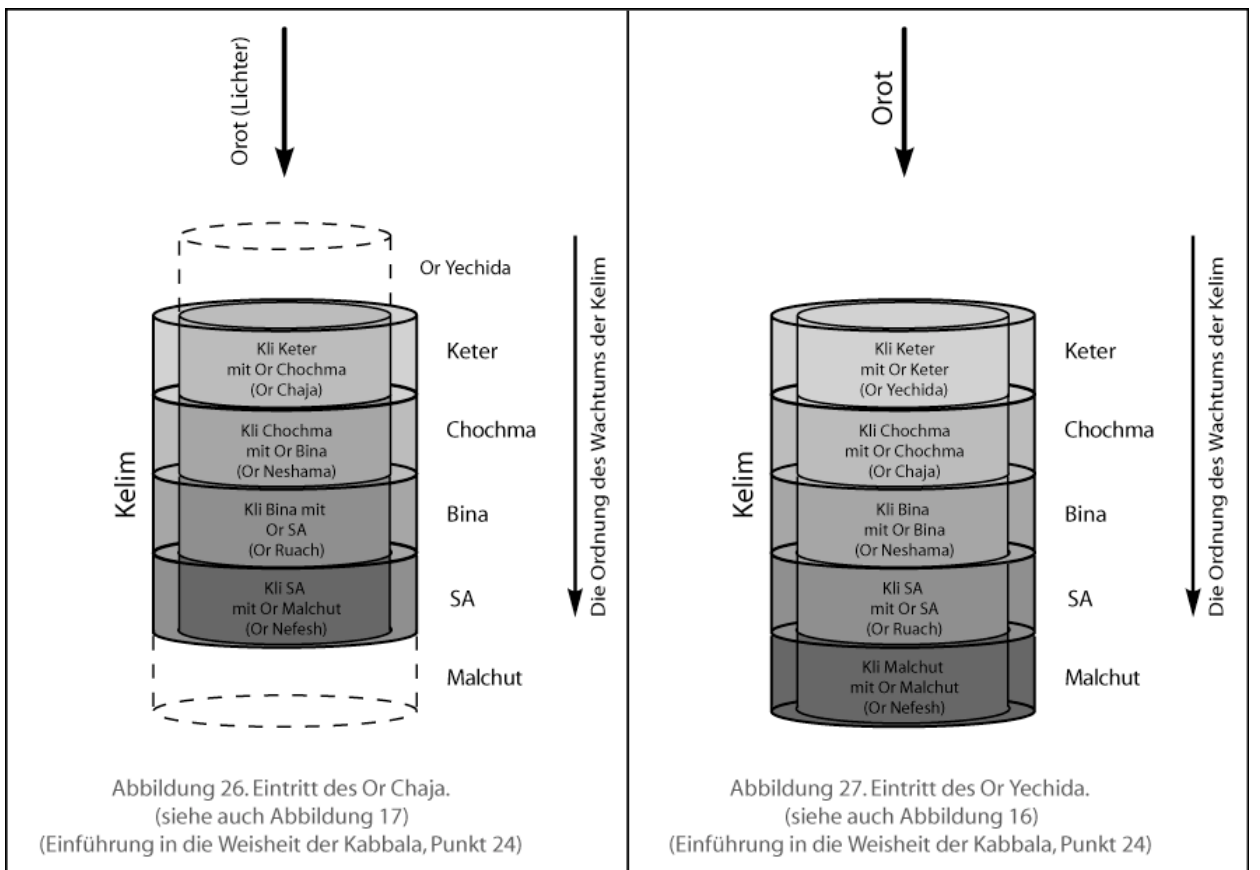
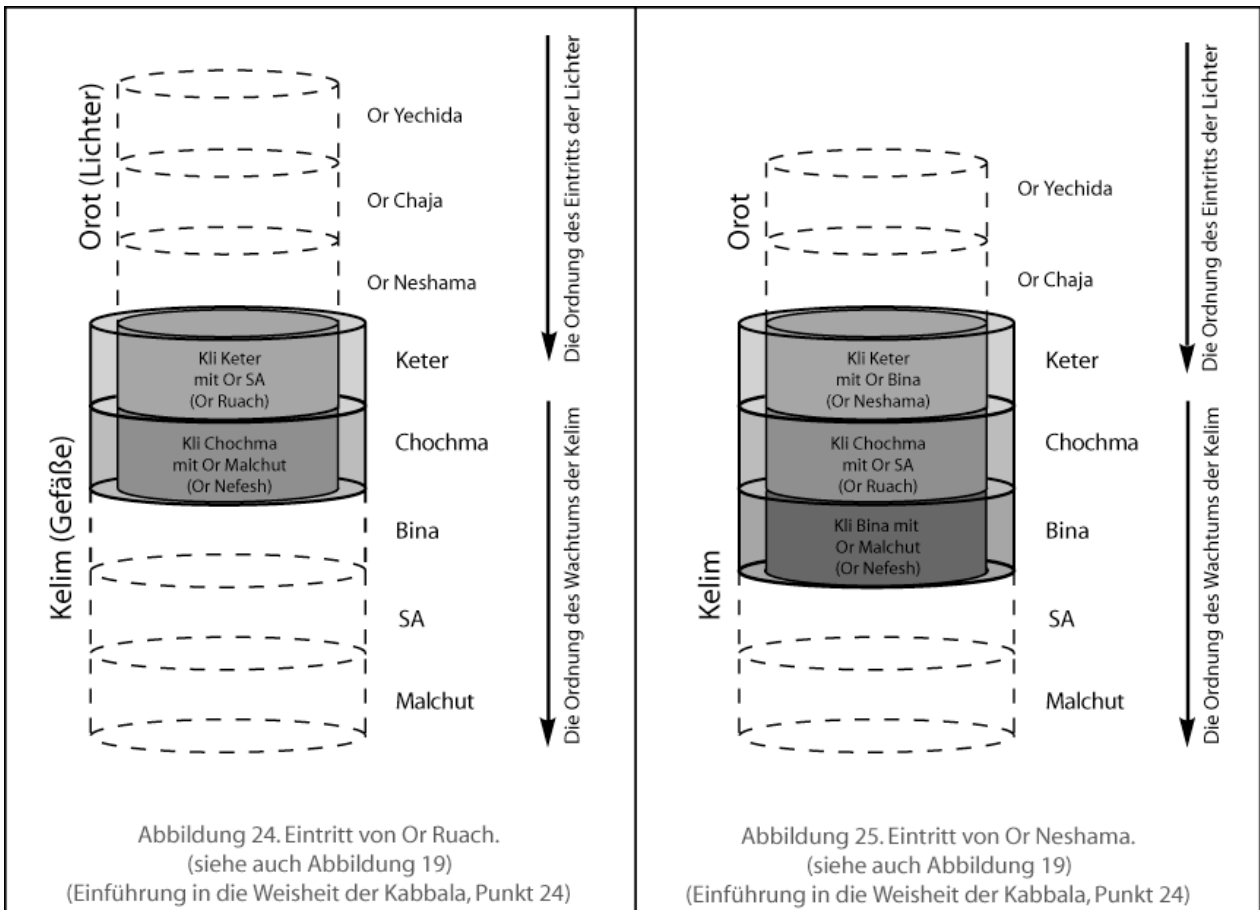

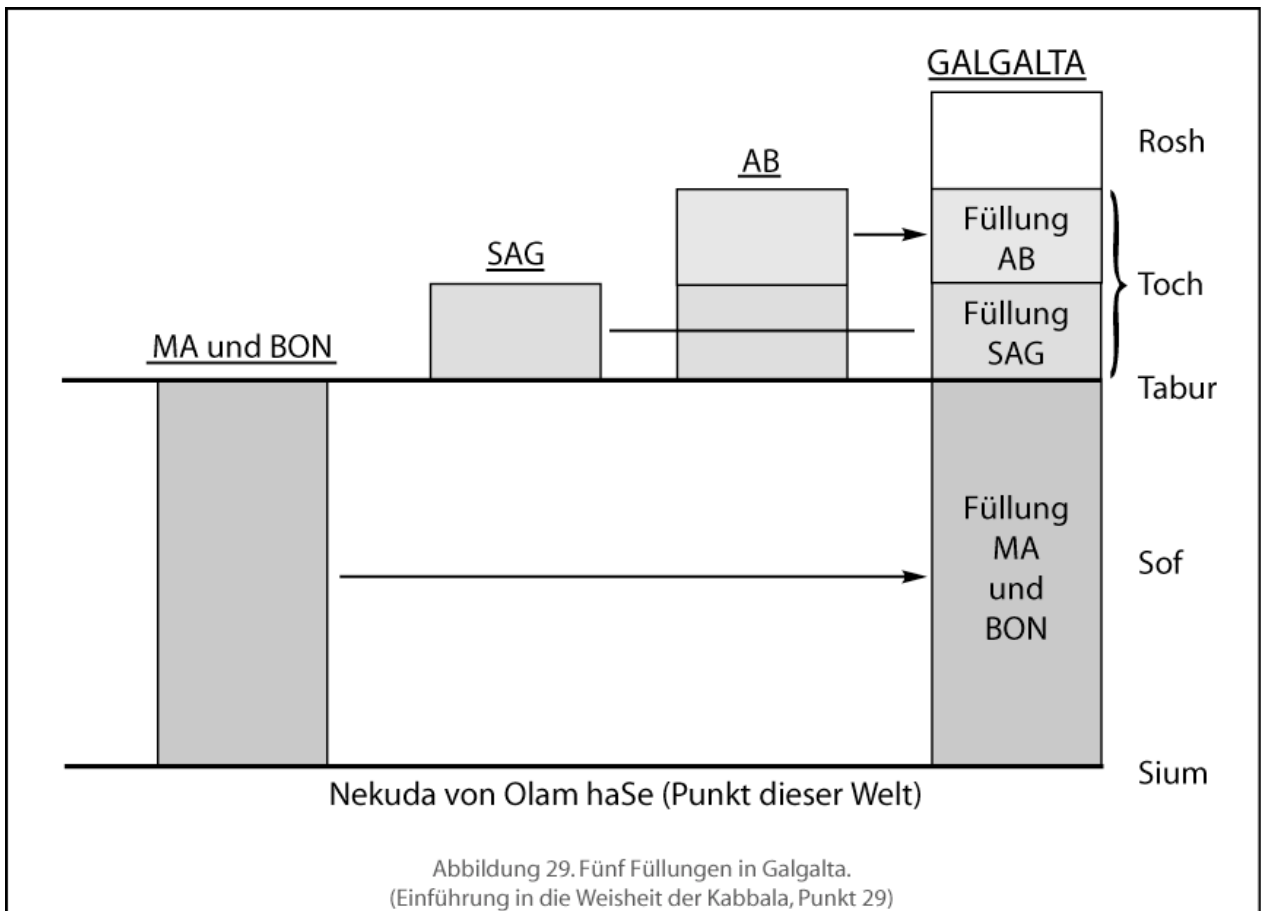
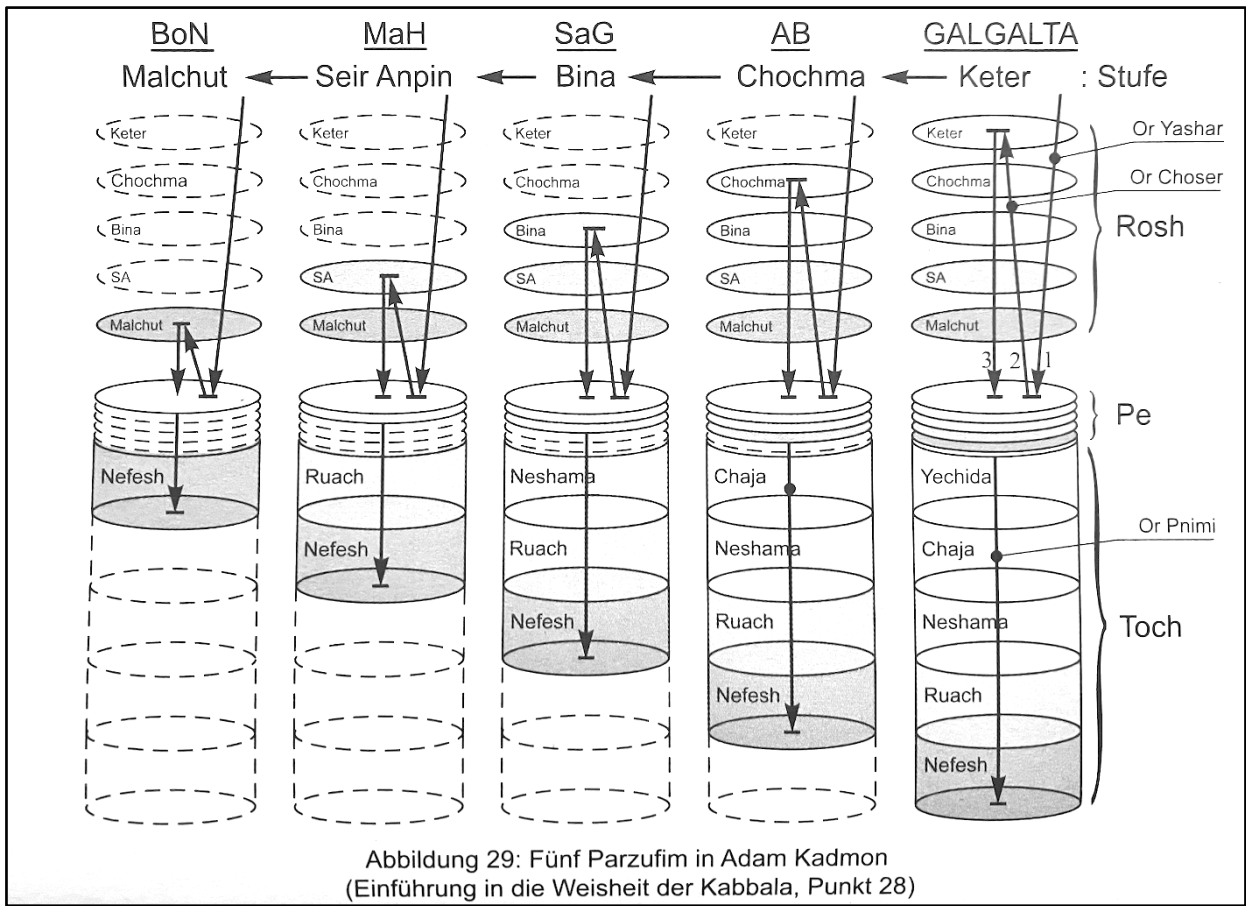

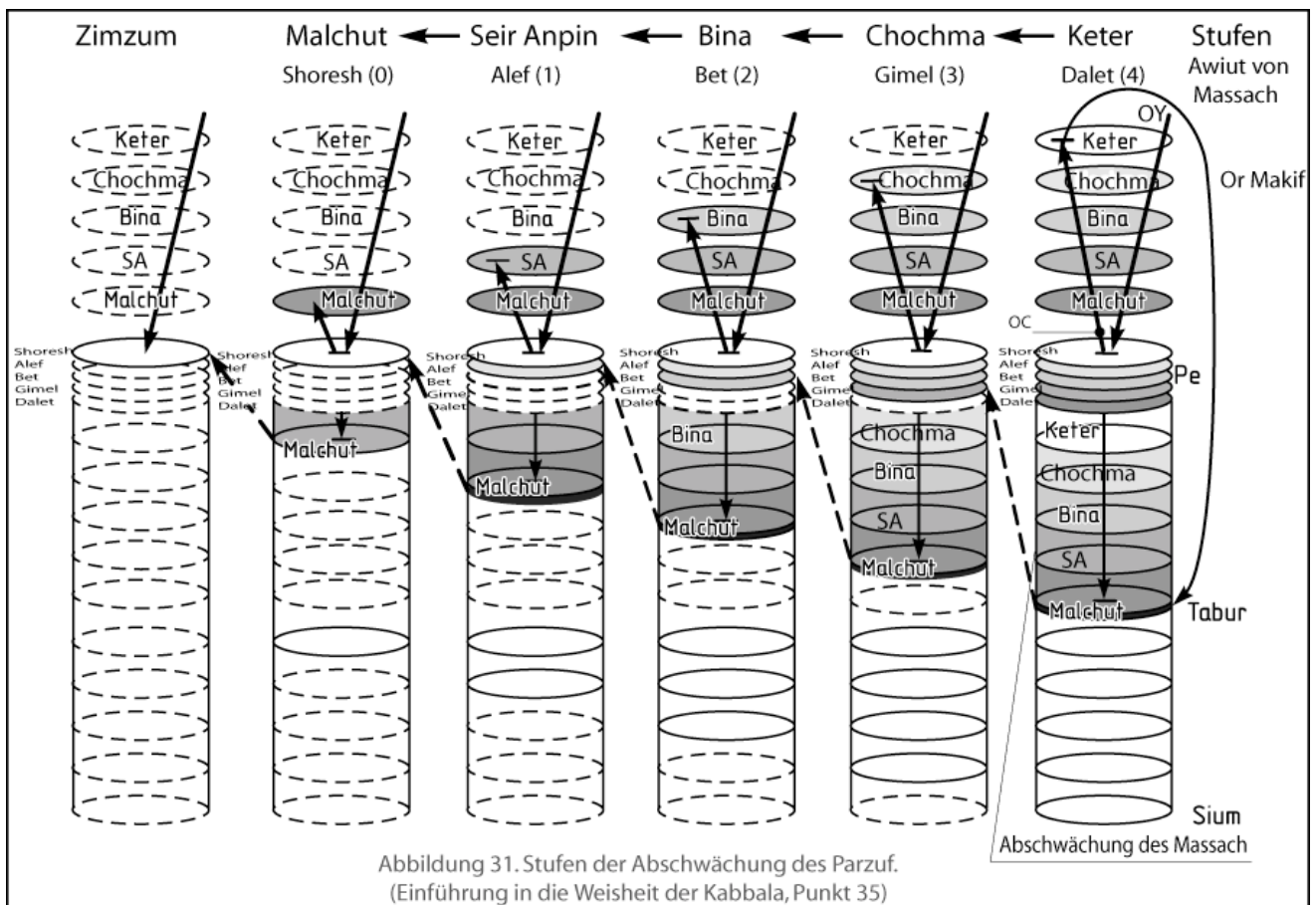
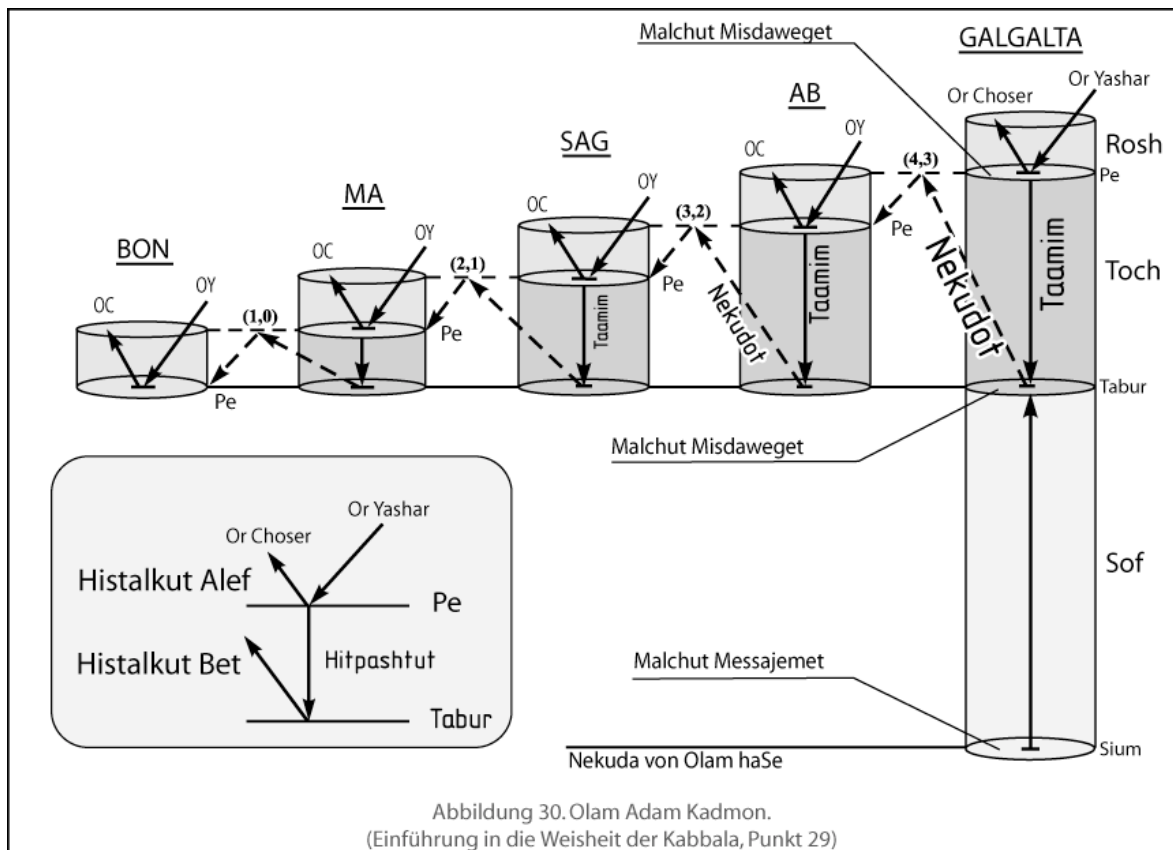

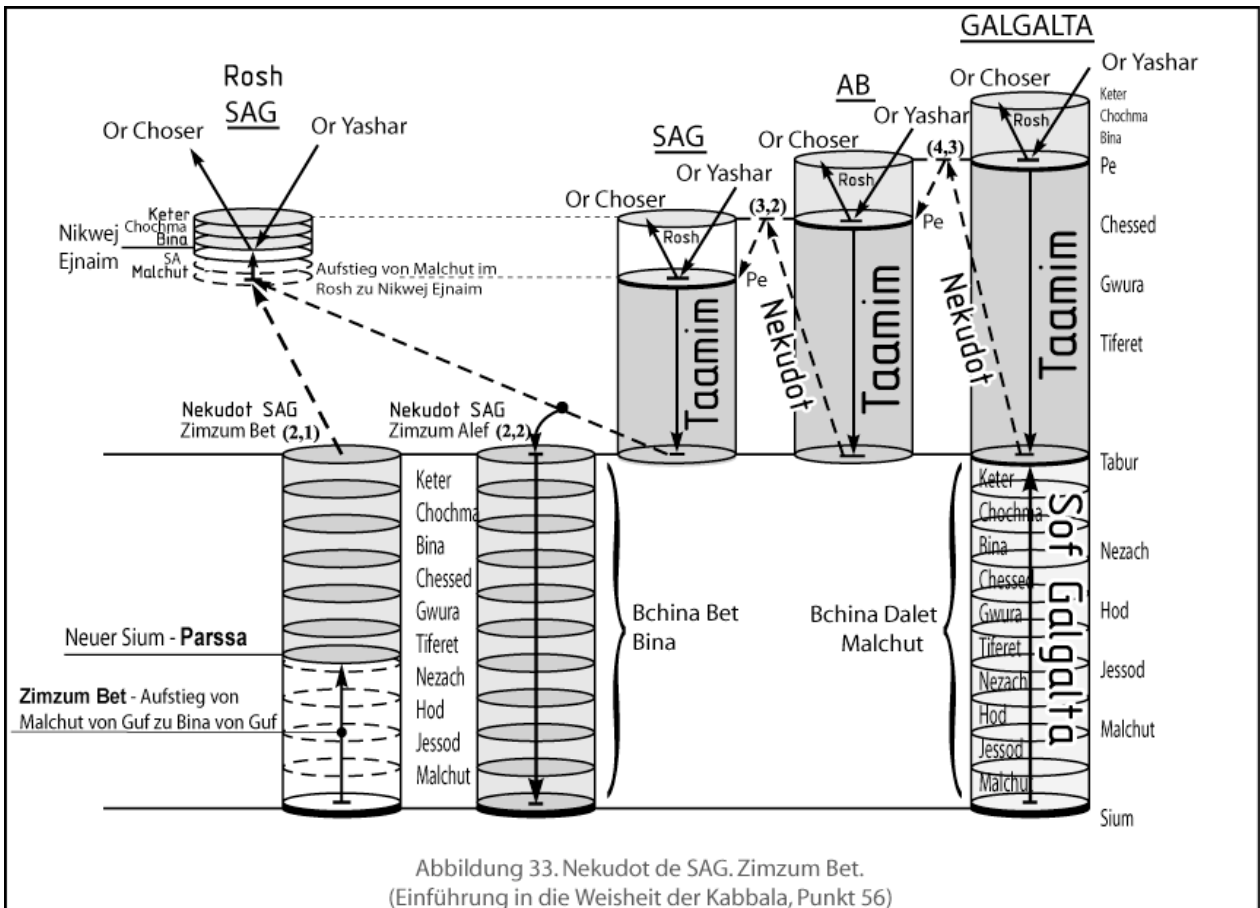
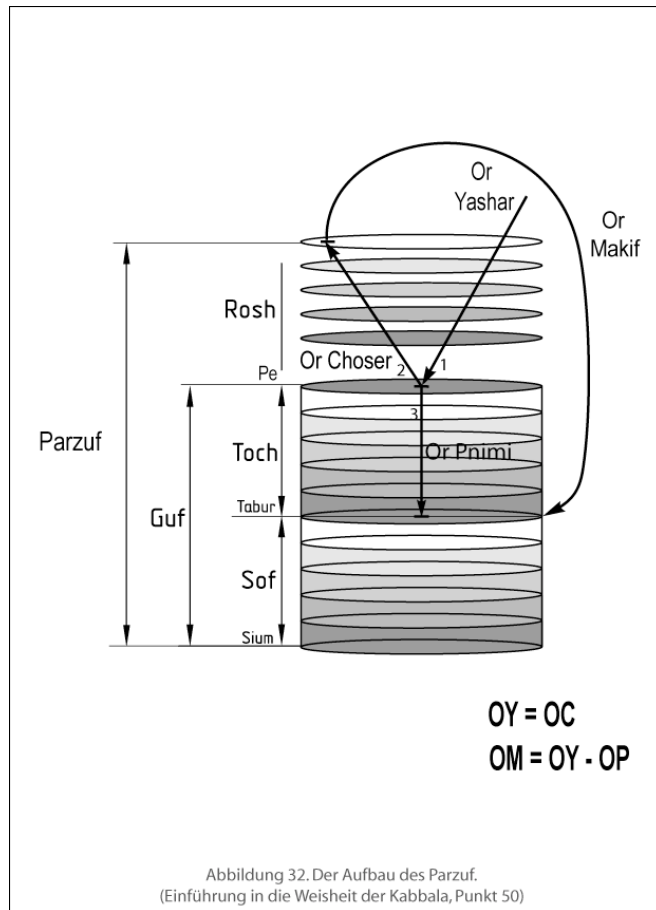

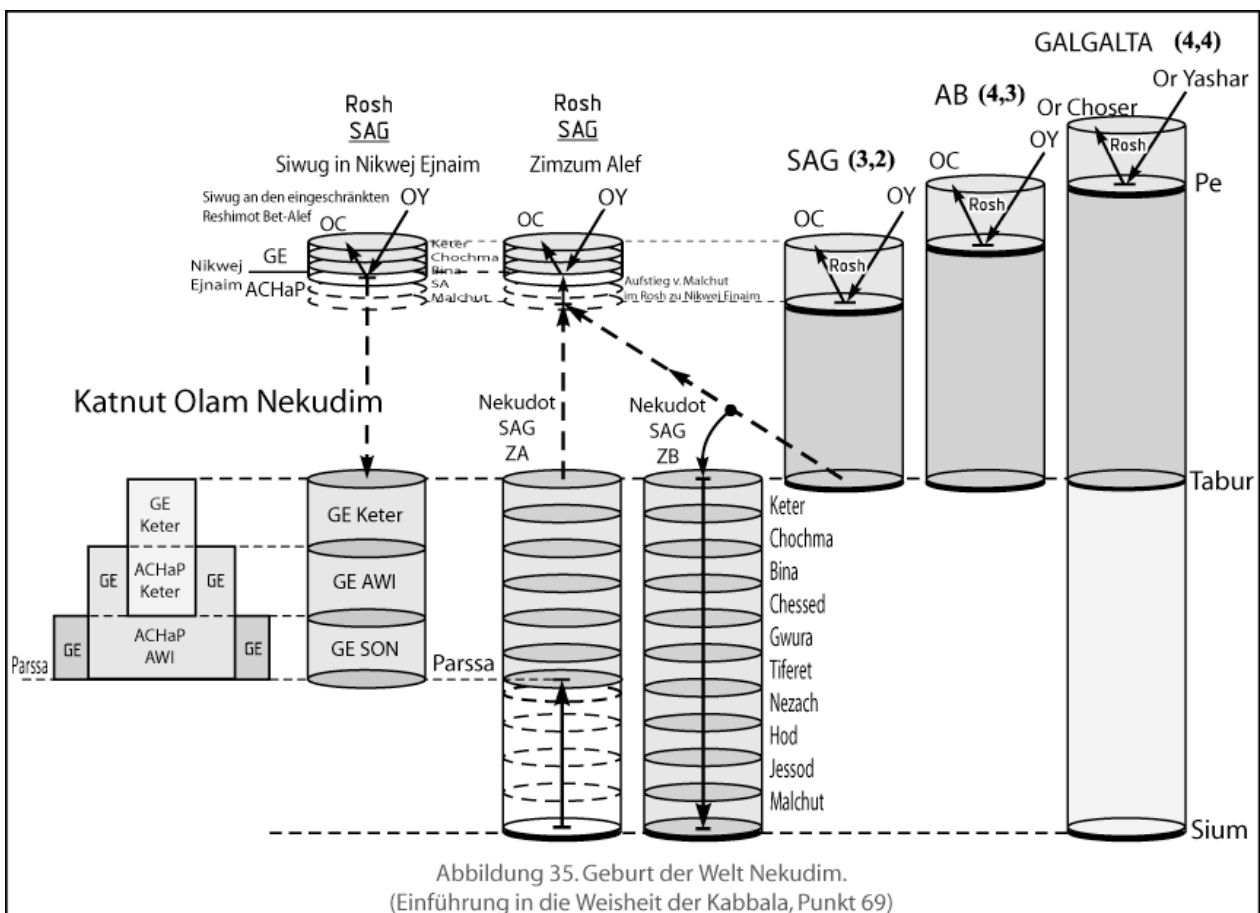
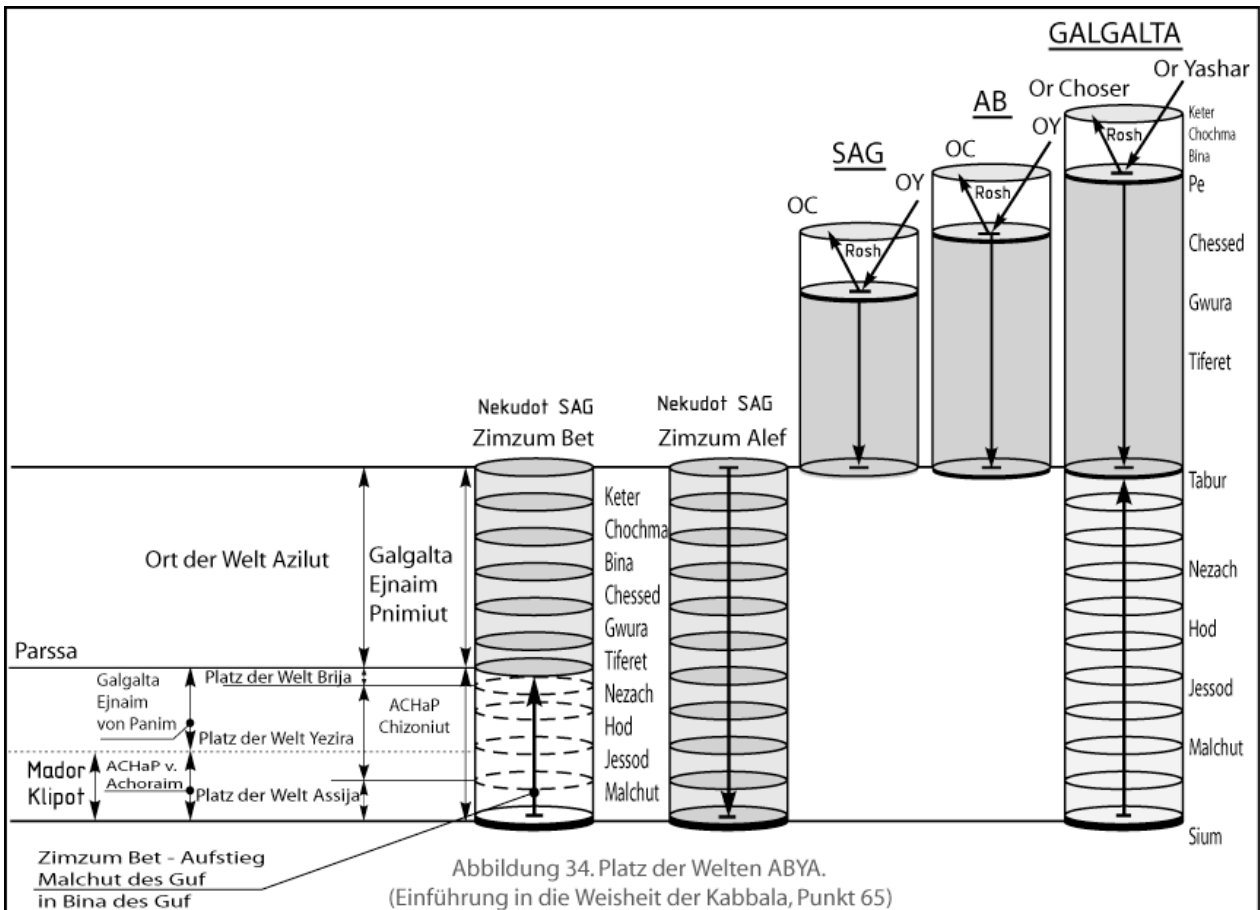

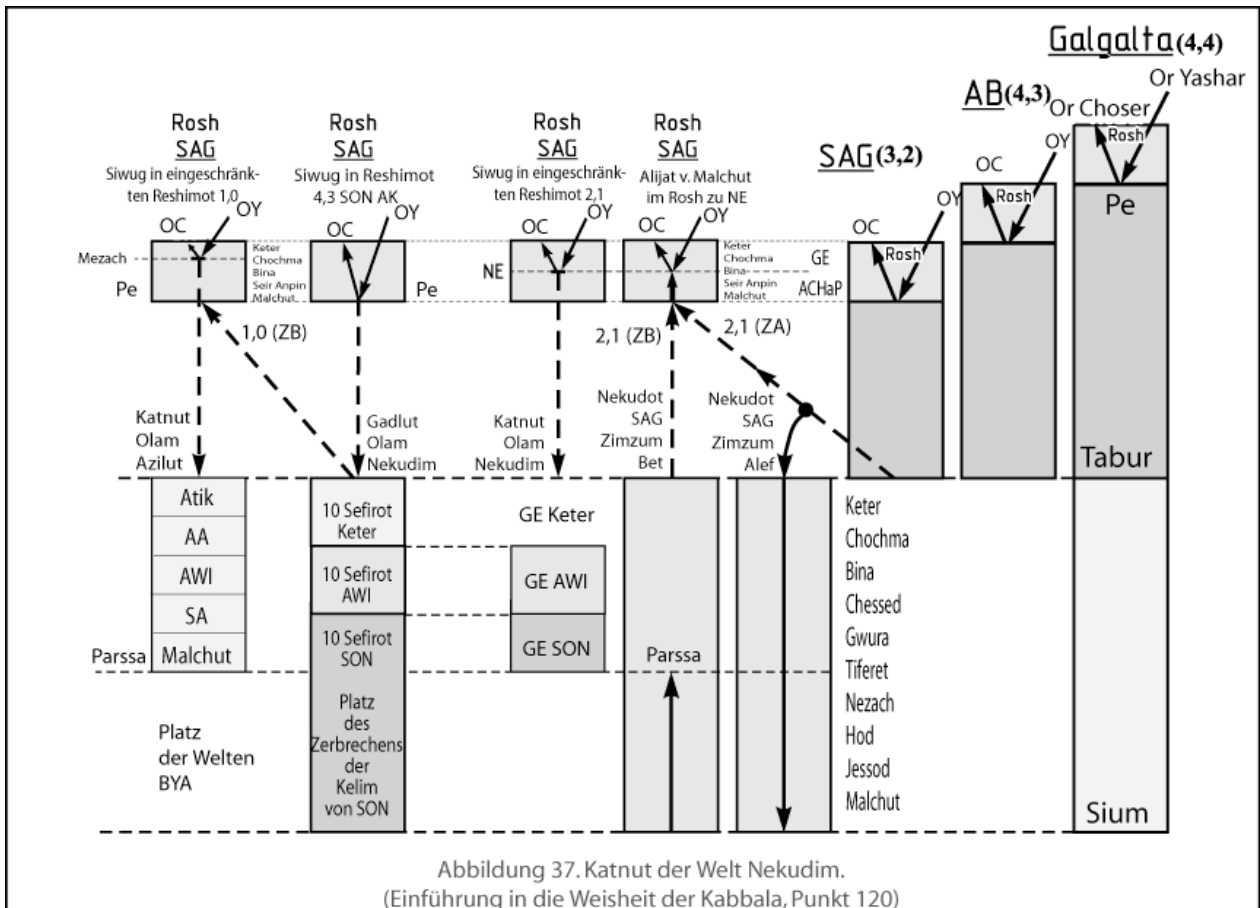
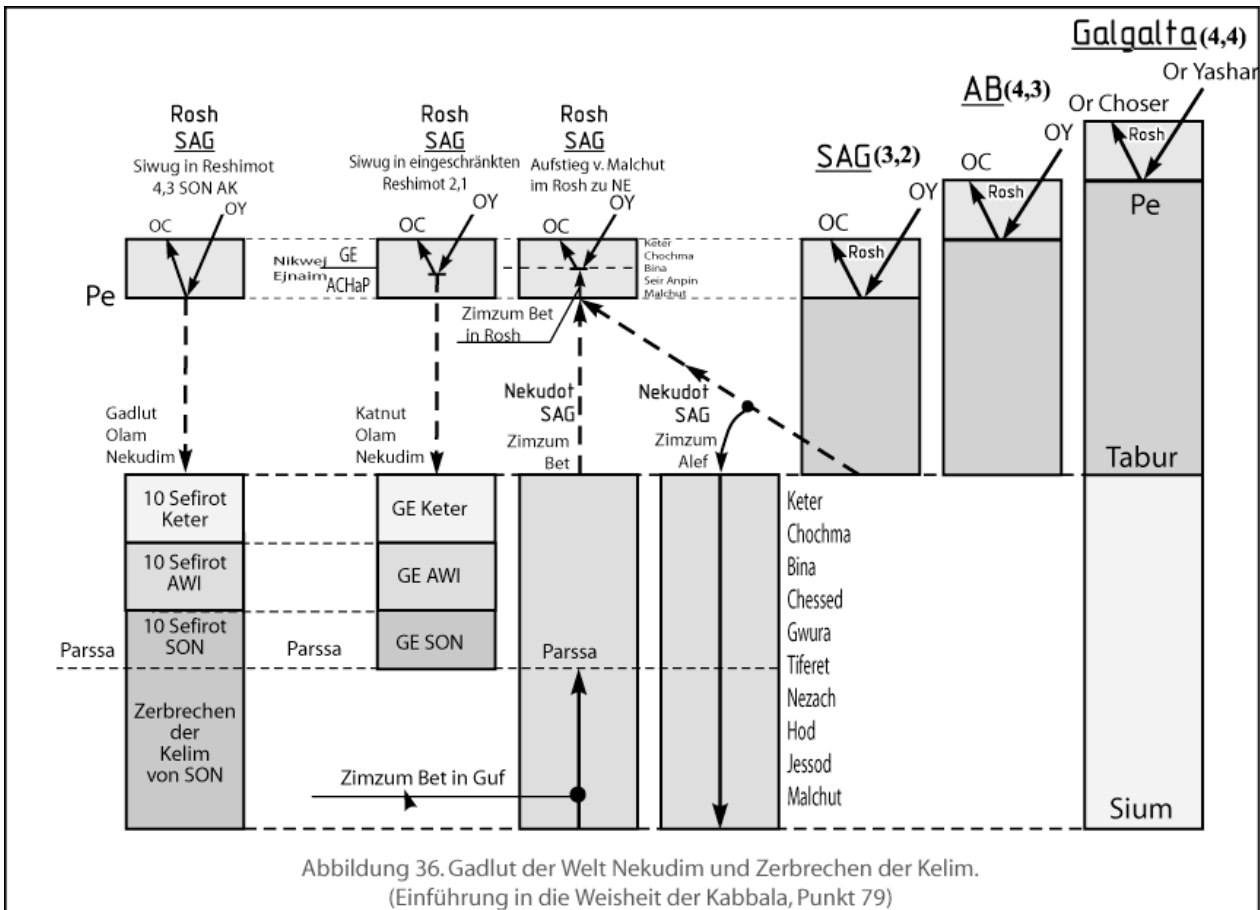

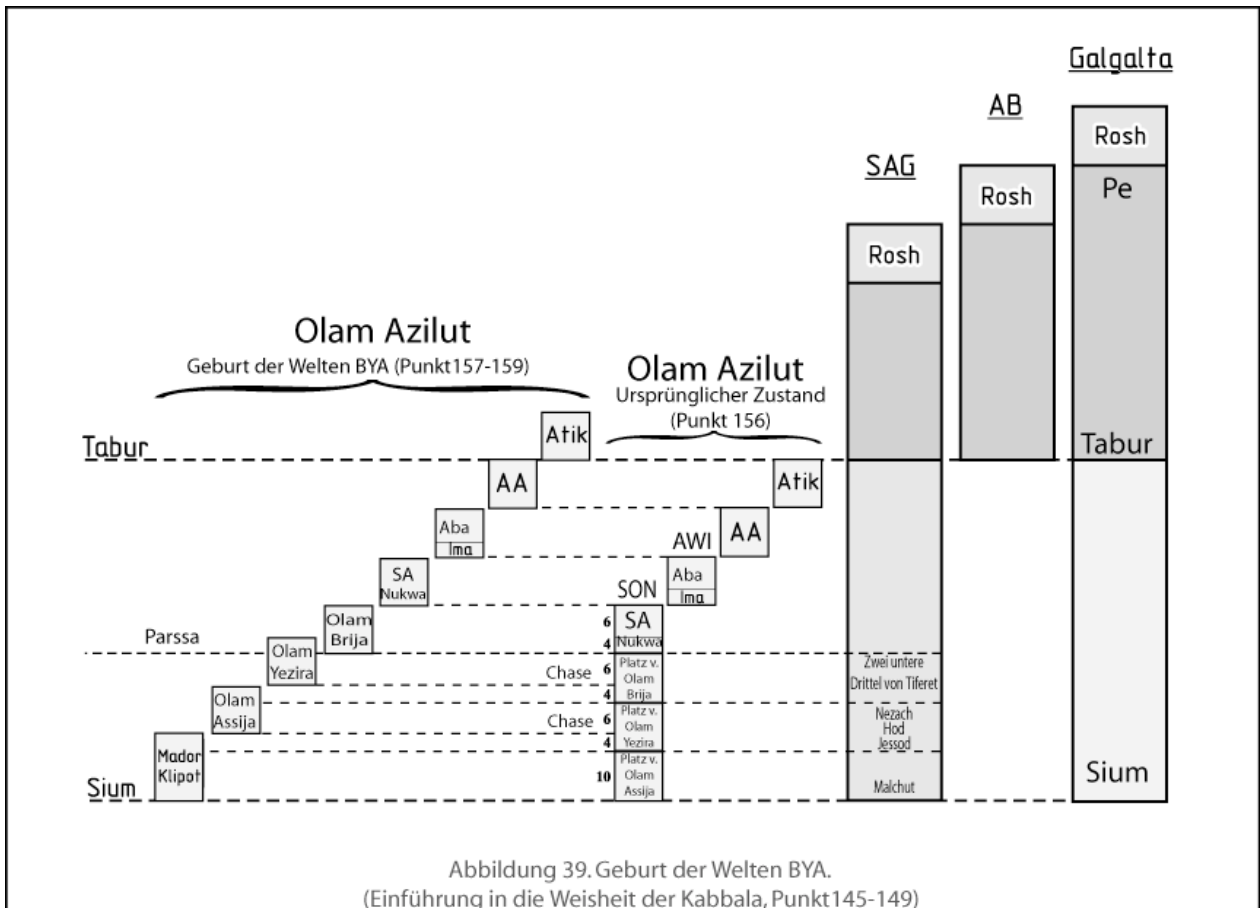
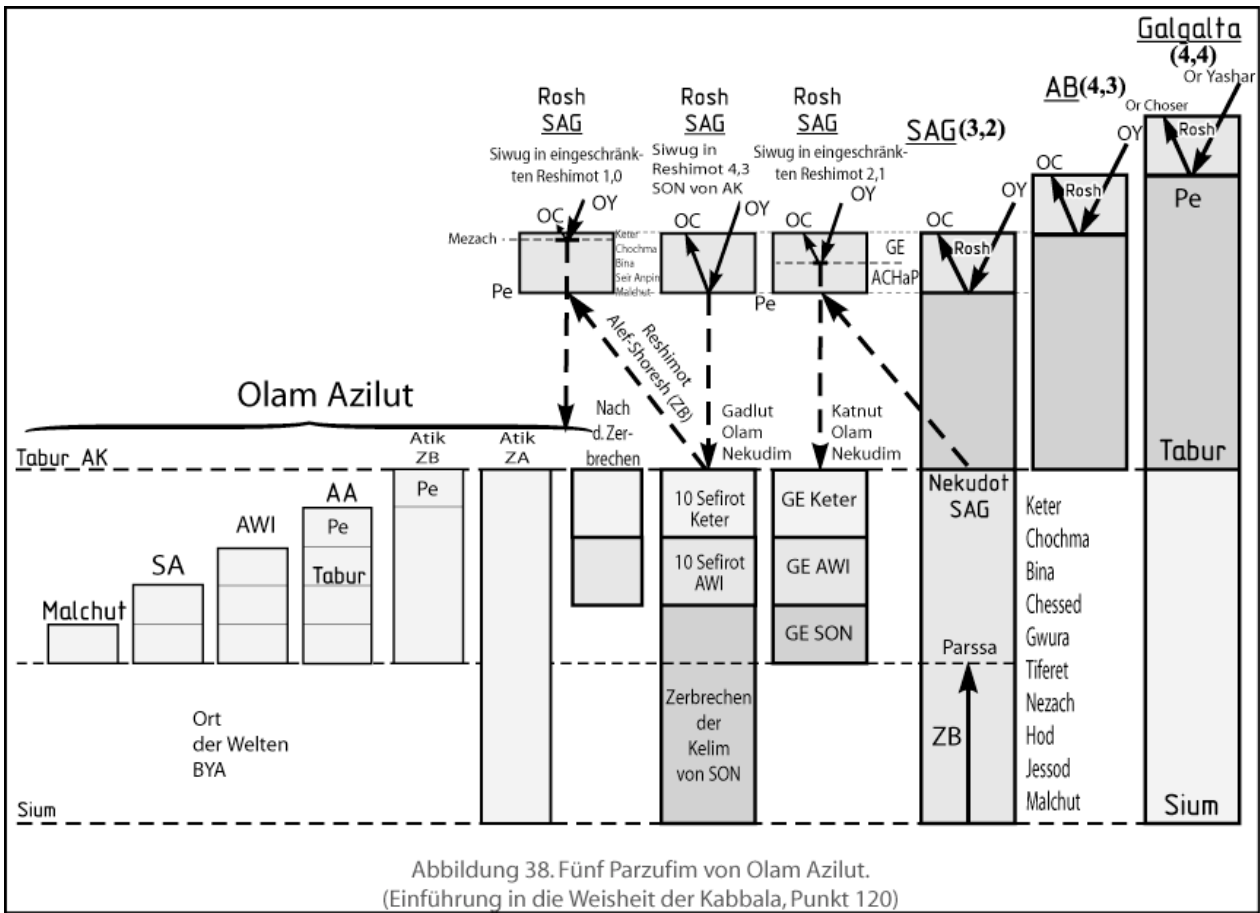

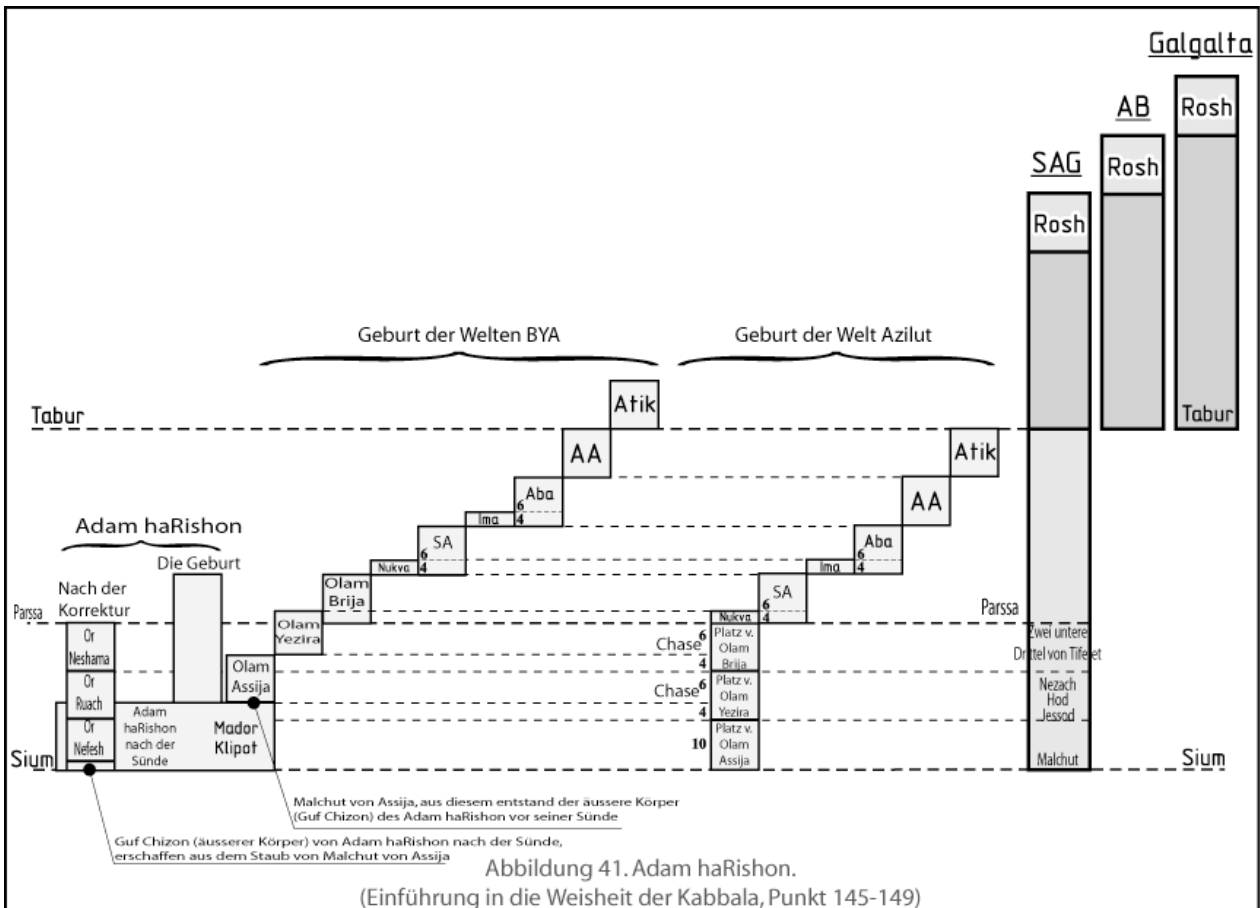
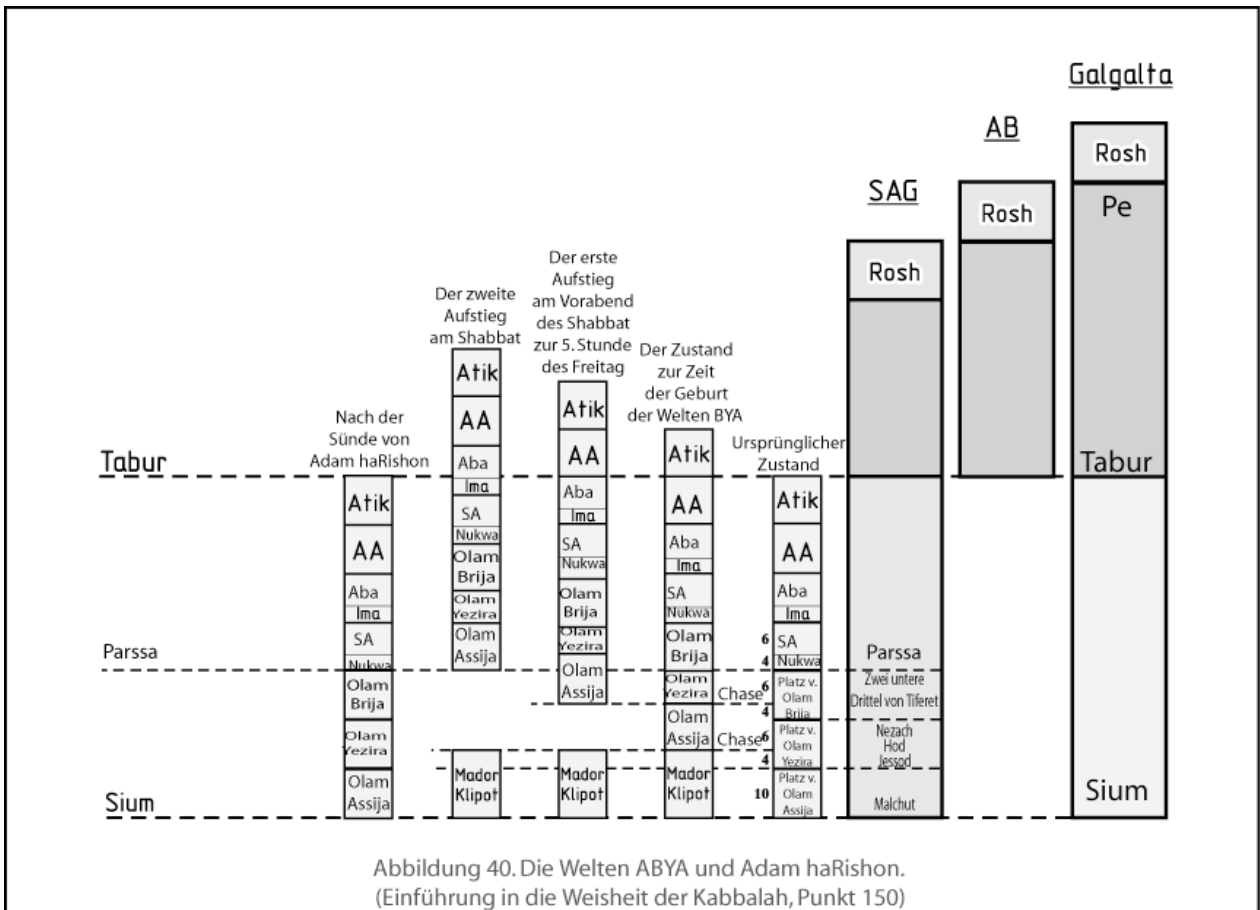

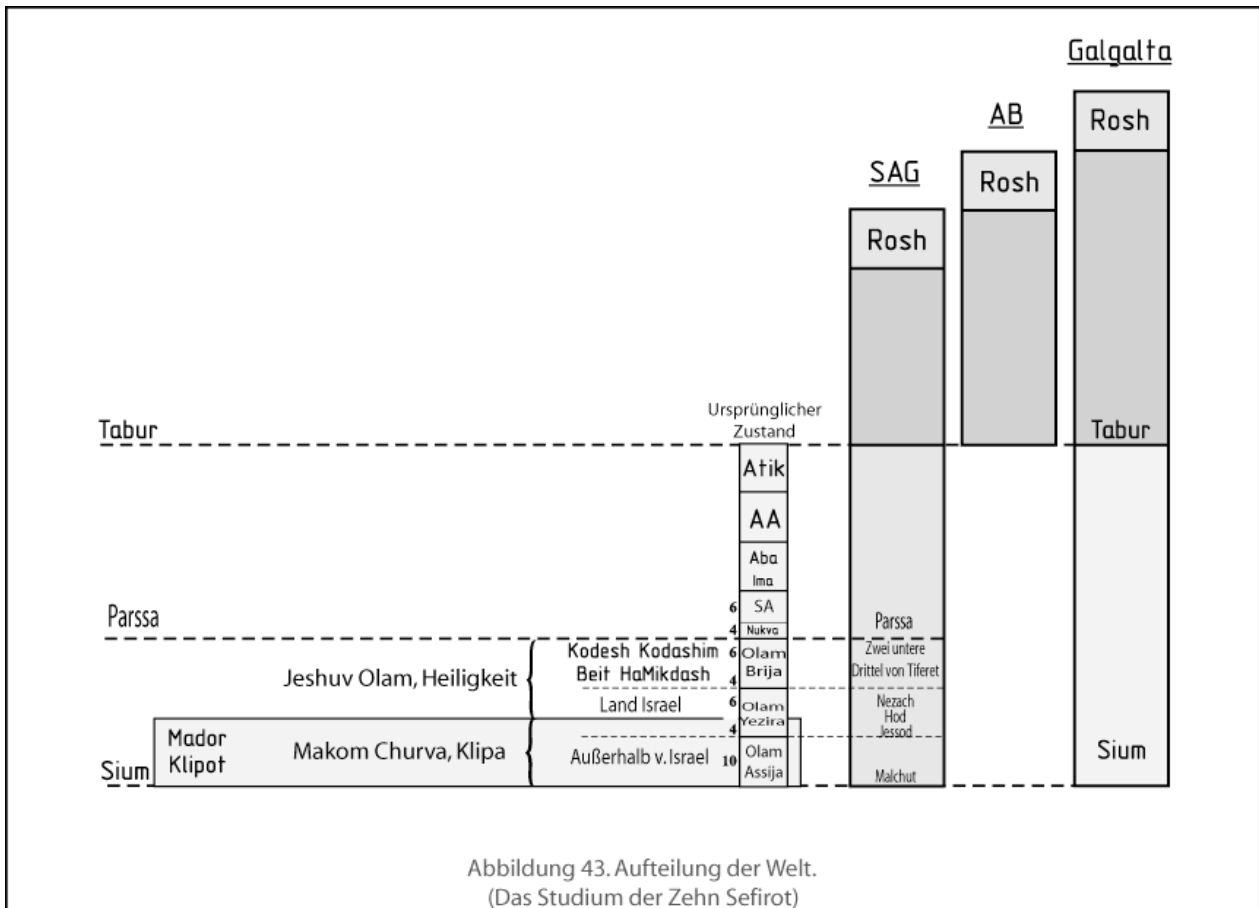
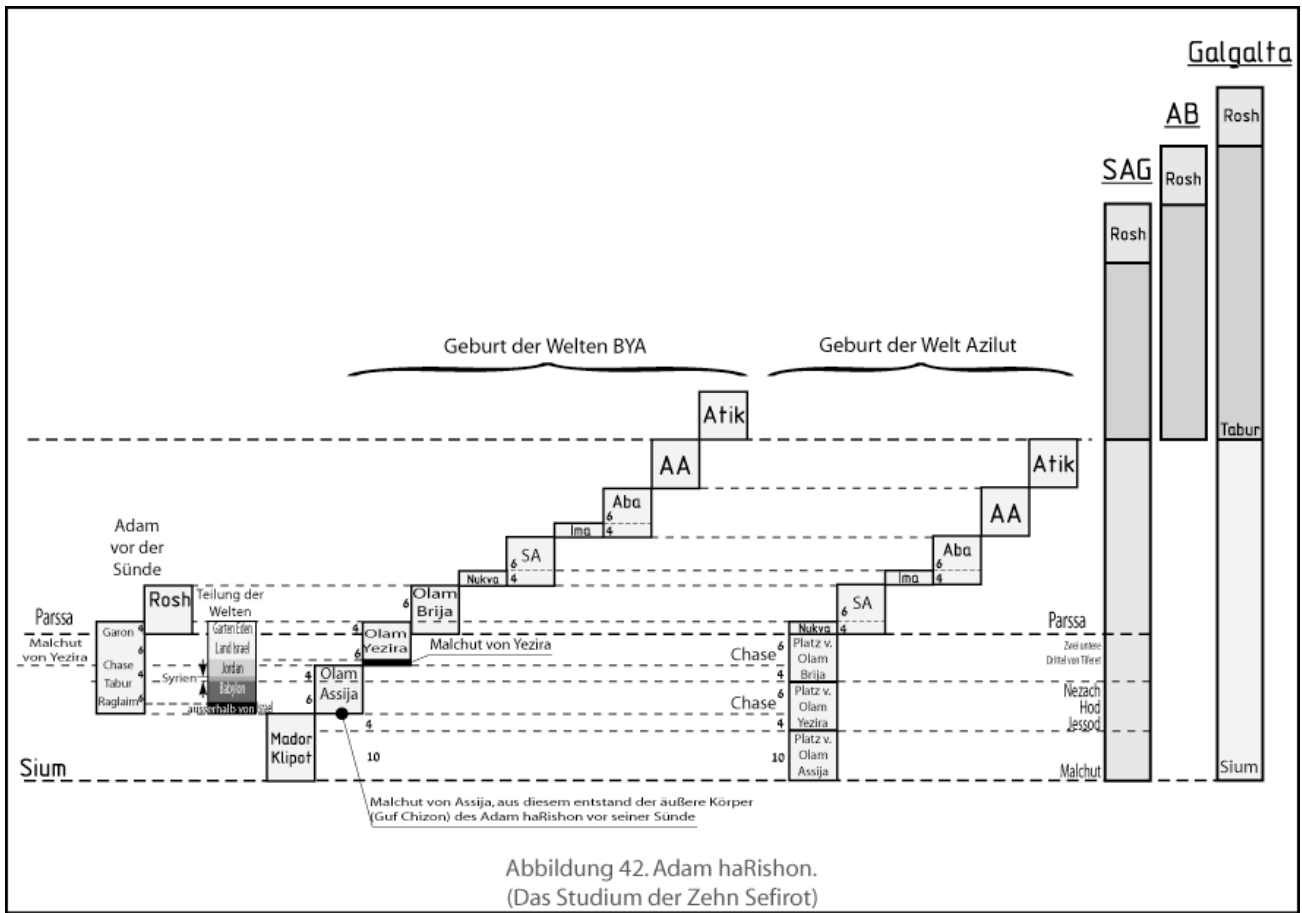

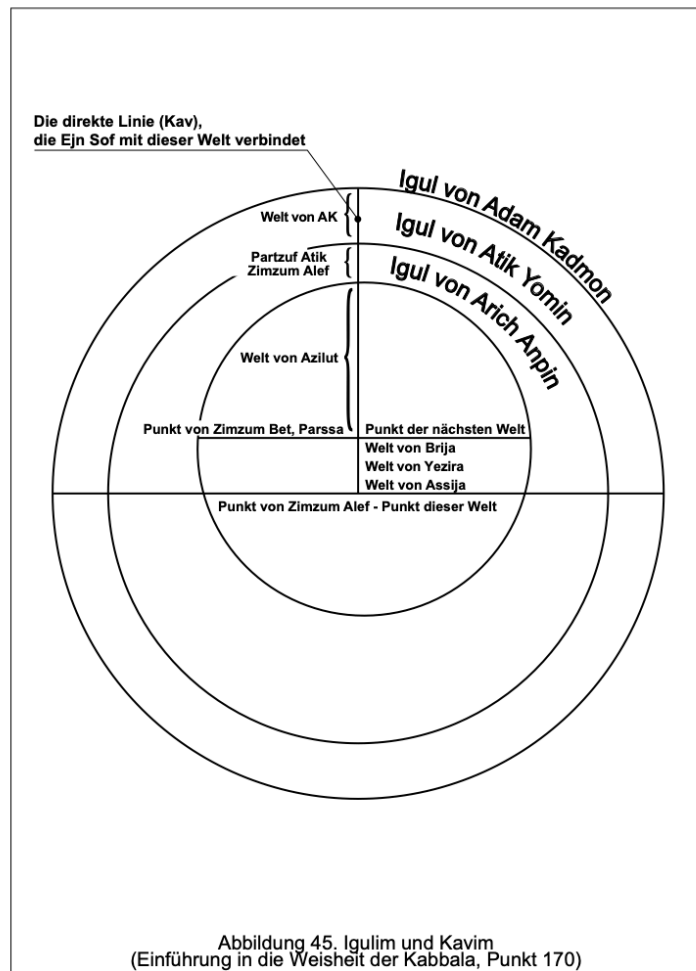
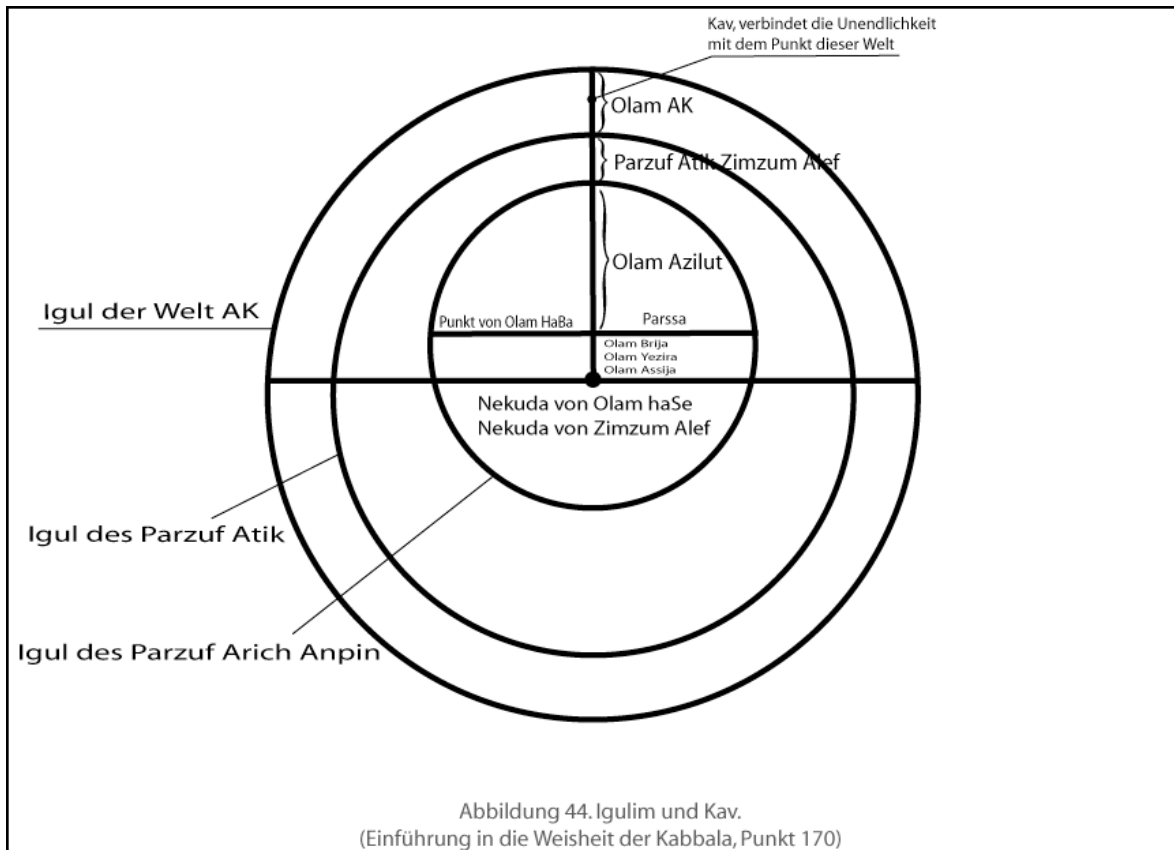

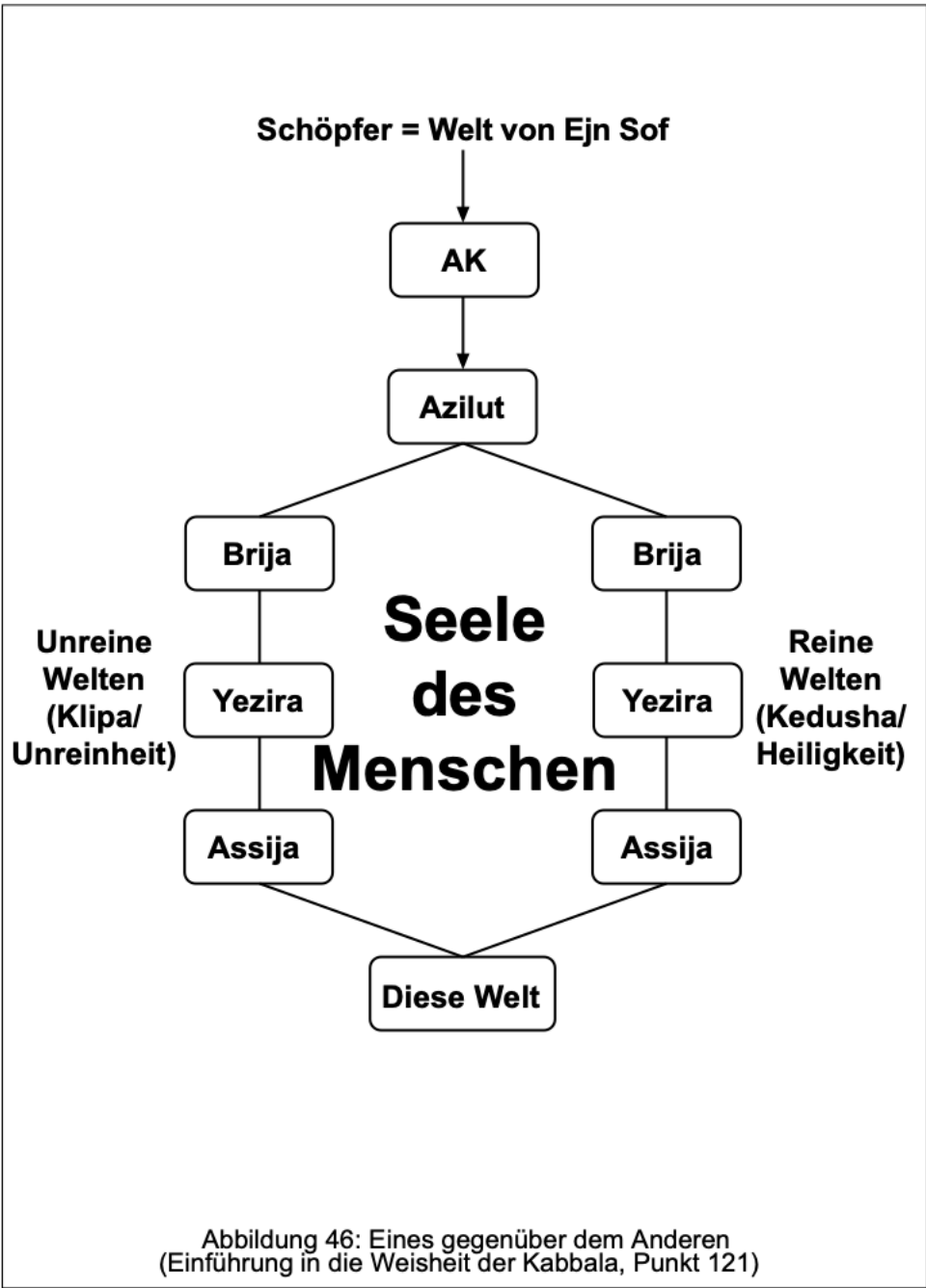



Abbildung 47: Zimzum Bet und Katnut
(Einführung in die Weisheit der Kabbala, Punkt 85)





Abbildung 49: Etappen in der Entwicklung des Parzuf
(Einführung in die Weisheit der Kabbala, Punkt 121)

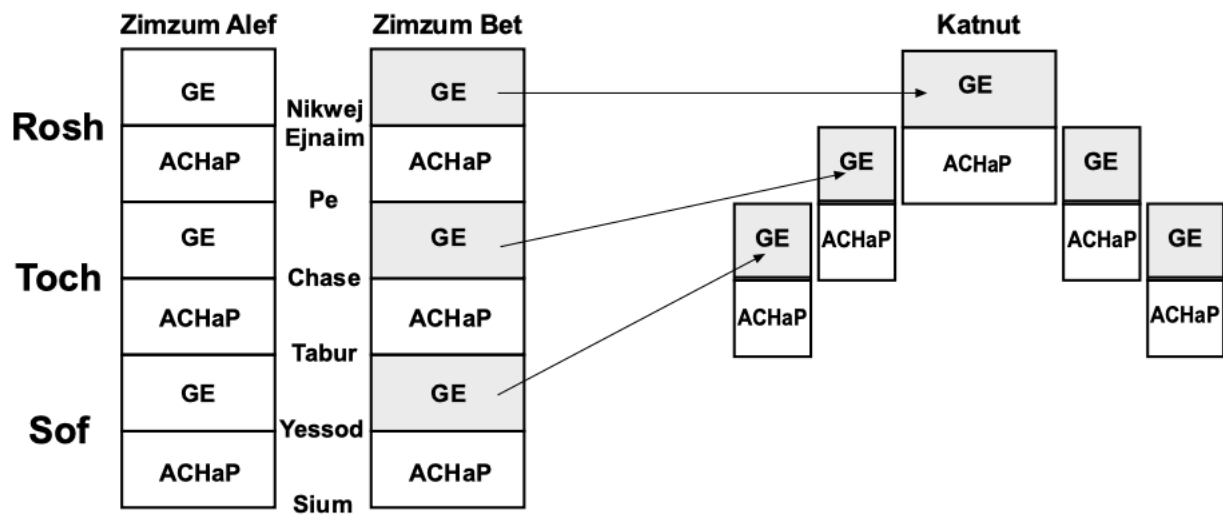
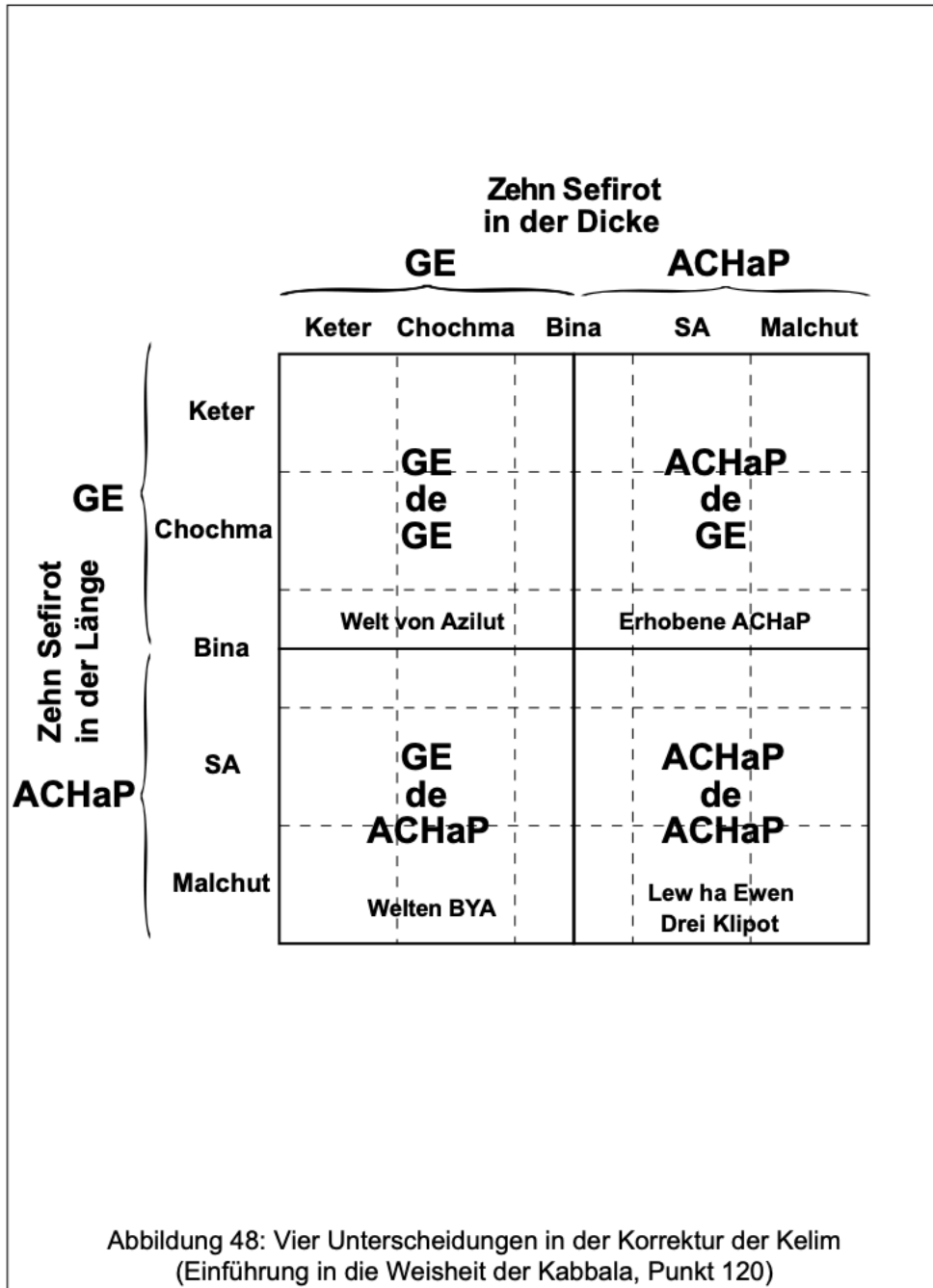

Abbildung 50: Sortieren der Kelim nach dem Zerbrechen
(Einführung in die Weisheit der Kabbala, Punkt 101)



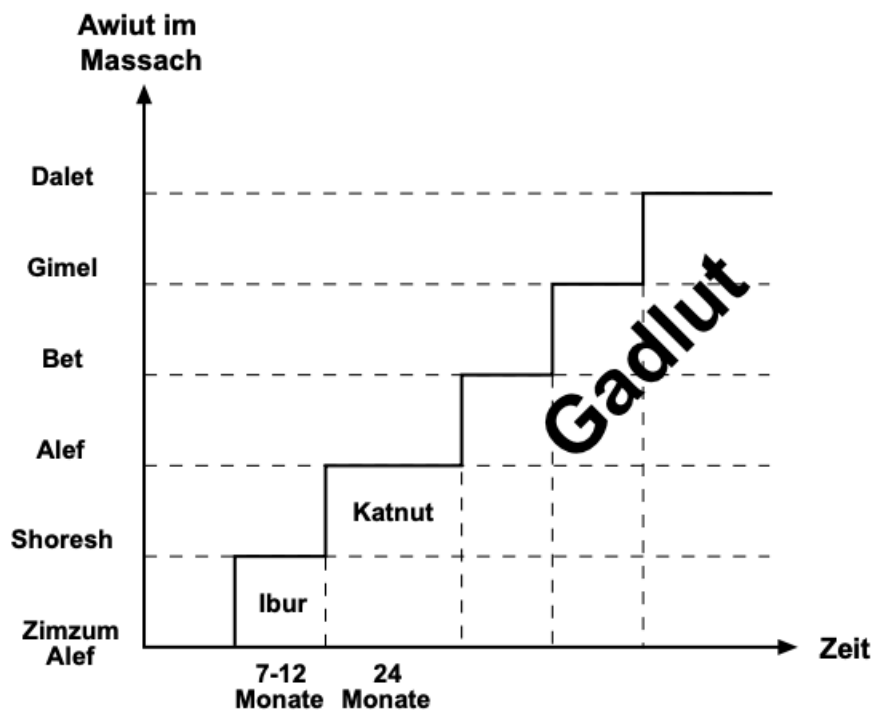

Abbildung 52: Einteilung des Parzuf
(Einführung in die Weisheit der Kabbala, Punkt 50)

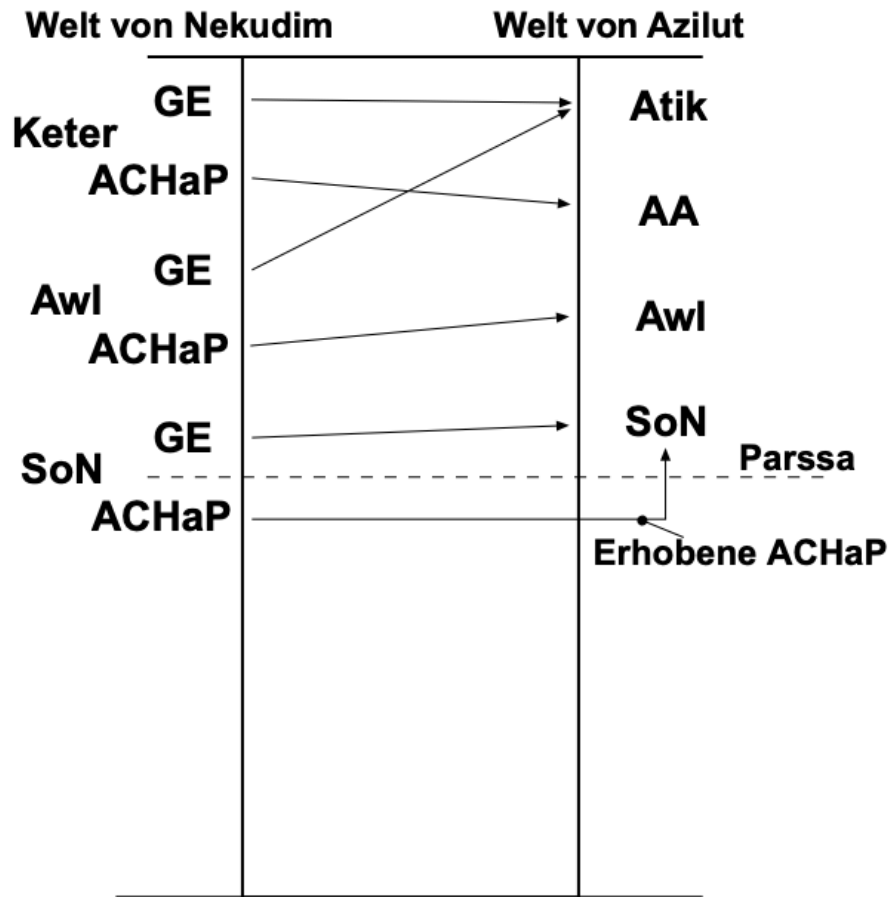
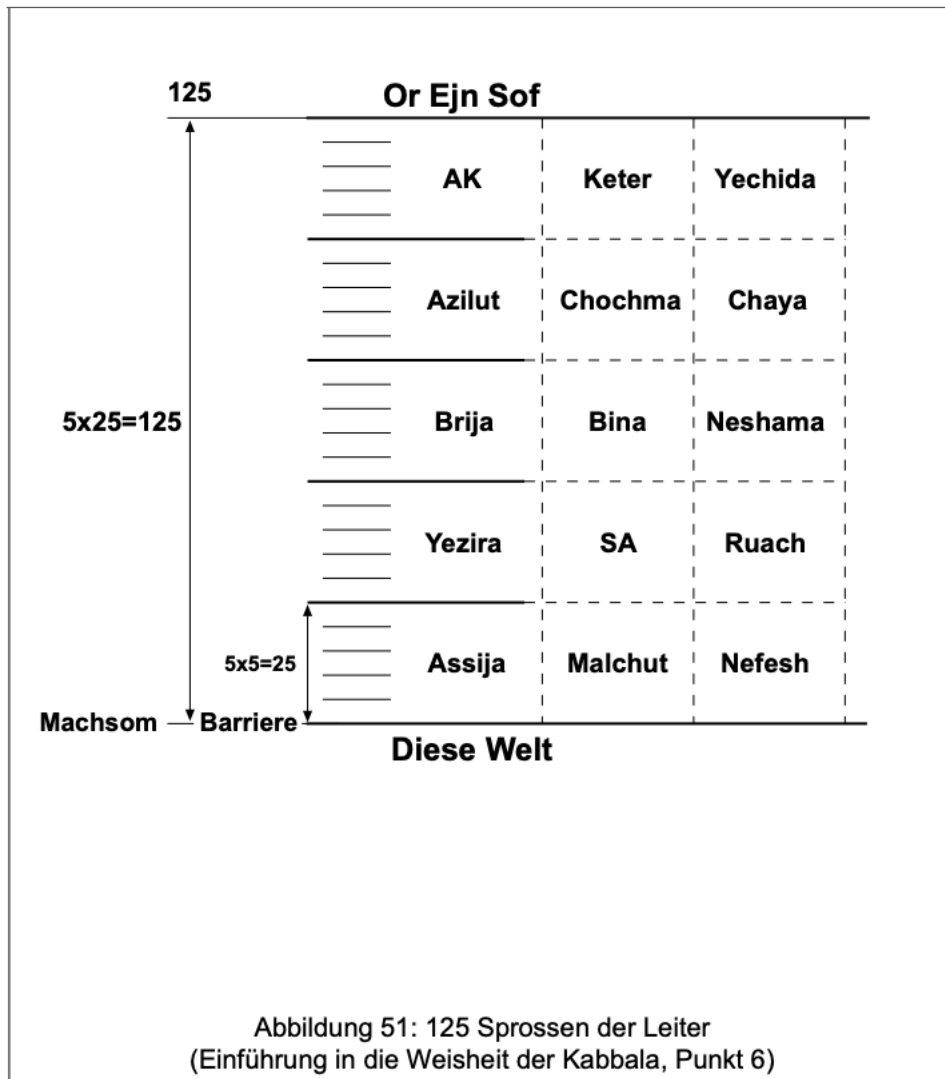
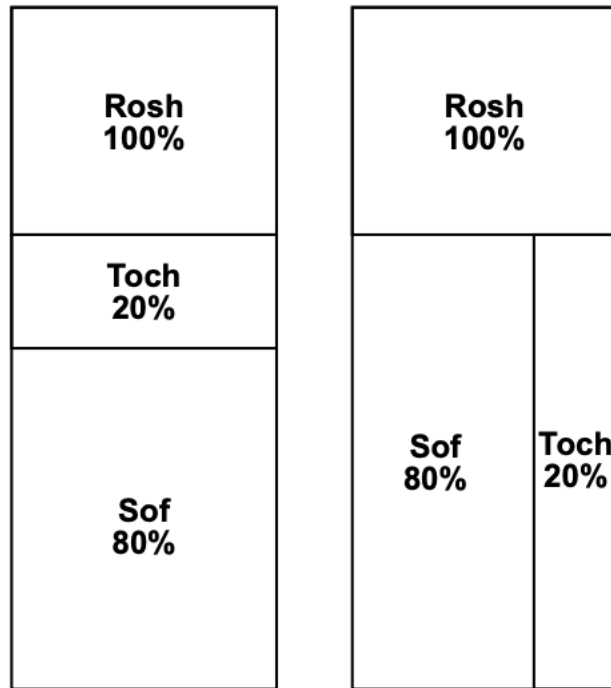
c

															Mensch						
Bchinot	HaWaYaH	Sefirot	Teile des Rosh	Sinne	Parzufim	Welten	Lichter	TaNTa	Vier Bchinot in der Natur	Vier Bchinot im Menschen	Zwischenstufen im Menschen	Spiritualität im Menschen	Körper des Menschen	Kleidung des Menschen	Haus des Menschen	BPTM	Zwischenstufe in der Natur	Richtungen			
Shoresh	Spitze von Yud	Keter	Gulgolet (Schädel)		Galgalta	Adam Kadmon	Yechida			(Shoresh) (Wurzel)		Yechida	Moach (Gehirn)								
Alef	Yud	Chochma	Ejnaim (Augen)	Sehen	AB	Azilut	Chaja	Taamim	Feuer	Neshama (Innerer Mensch)	Dam (Blut) Se'arot (Haare) Zipornaim (Nägel) Ohalim (Zelte)	Chaja	Azamot (Knochen)	Kutonet (Hemd)	Bait (Haus)	Sprechend	Affe	Süden (heiß und trocken)			
Bet	Hej	Bina	Osen (Ohr)	Hören	SaG	Brija	Neshama	Nekudot	Wind	Guf (Körper)		Neshama	Gidin (Sehnen)	Michnasajim (Hosen)	Chazer (Hof)	Tierisch		Hund des Feldes	Norden (kalt und feucht)		
Gimel	Waw	Seir Anpin	Chotem (Nase)	Schmecken	MaH	Yezira	Ruach	Tagin	Wasser	Lewush (Kleidung)		Ruach	Bassar (Fleisch)	Miznefet (Hut)	Sade (Feld)	Pflanzlich	Korallen	Westen (heiß und feucht)			
Dalet	Hej	Maichut	Pe (Mund)	Sprechen	BoN	Assija	Nefesh	Otiot	Staub	Bait (Haus)		Nefesh	Or (Haut)	Awnet (Gürtel)	Midbar (Wüste)	Bewegungslos		Osten (kalt und trocken)			

Abbildung 53: Allgemeine Bezeichnungen (Talmud Esser Sefirot, Band 3, Kapitel 4-5)